

Designing Components of ABC Test Loop to Achieve Break-Even Conditions

Tae Woo Kim, Gihyeon Kim, Jeong Ik Lee*

Dept. Nuclear & Quantum Eng., KAIST, 291 Daehak-ro, Yuseong-Gu, Daejeon 34141, Republic of Korea

*Corresponding author: jeongiklee@kaist.ac.kr

*Keywords : sCO₂ Brayton cycle, Break-even cycle

1. Introduction

The supercritical carbon dioxide (S-CO₂) Brayton cycle has emerged as a strong candidate for power conversion in Generation IV nuclear reactors due to its high thermal efficiency, compact system layout, and compatibility with elevated operating temperatures. Generation IV reactors are designed to operate at temperatures higher than those of conventional light water reactors, enabling improved thermal efficiency compared to traditional power plants. The S-CO₂ Brayton cycle provides a safe and efficient power conversion option particularly well matched to advanced nuclear systems.[1]

The Autonomous Brayton Cycle (ABC) test loop at Korea Advanced Institute of Science and Technology (KAIST) was constructed to experimentally investigate S-CO₂ cycle technology. However, the current experimental facility operates with negative efficiency. To improve the system, the compressor needs less power than the turbine produces.

This study presents a redesigned loop configuration and key component specifications of the previously installed S-CO₂ Brayton cycle system aimed at achieving break-even operation, which the compressor power is the same as the turbine power. The proposed design focuses on optimizing thermal management and component performance to maximize cycle efficiency under constrained heating conditions. This study finds the break-even point by increasing the maximum temperature of the cycle under the current conditions. After that, design the components that satisfy the calculated inlet and outlet conditions. Pressure drop generated in the piping and heat dissipation were not considered in the calculation.

Achieving break-even operation in the ABC test loop is expected to significantly enhance experimental capability and provide valuable operational experience and data for the development and validation of S-CO₂ Brayton cycle technology applicable to future Generation IV nuclear power systems.

2. Methods and Results

2.1 Cycle Configuration and Initial analysis

ABC test loop has been built in KAIST for the integral test of simple recuperated S-CO₂ cycle [2]. It consists of a pre-cooler, compressor, recuperator, heater,

and turbine. Table 1 and Figure 1 show the design parameters and layout of ABC Test Loop.

Table 1. Design parameters of ABC Test Loop

Parameter	Value
Compressor pressure ratio	1.2
Minimum temperature	35.0°C
Turbine efficiency	55%
Compressor efficiency	55%
Recuperator effectiveness	75%
Recuperator pressure drop	100kPa
Heat pressure drop	50kPa
Precooler pressure drop	100kPa
Mass flowrate	1.5kg/sec

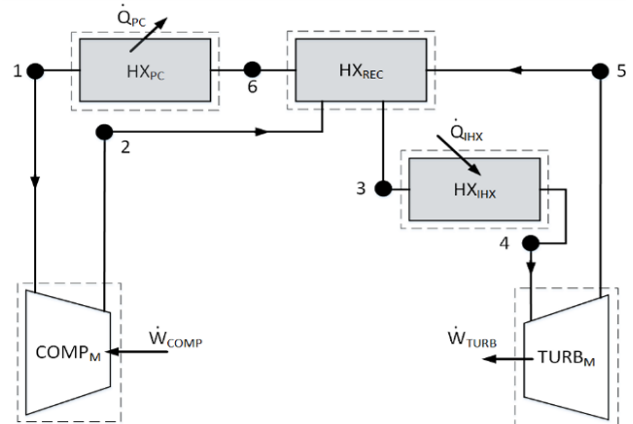

Fig. 1. Layout of simple recuperated cycle

The cycle analysis was performed with an in-house code KAIST-CCD (Closed Cycle Design). The design process finds the maximum temperature and heat input to achieve cycle efficiency above zero.

The efficiency of the loop was calculated by varying the maximum temperature while the minimum pressure and minimum temperature were fixed near the critical point of CO₂. When achieving the break-even conditions of the cycle, the maximum temperature was 363.0°C and the required heat input was 206kW. Table 2 and Figure 2 show the pressure and temperature distribution at each point and T-S diagram in the calculated cycle under the break-even conditions. Table 3 shows the Comparison of the main parameters of the cycle under initial and break-even conditions.

Table 2. Pressure and temperature for each point

	Pressure (bar)	Temperature (°C)
1	76.0	35.0
2	91.2	47.81
3	90.2	243.19
4	89.7	363.0
5	78.0	353.34
6	77.0	105.74

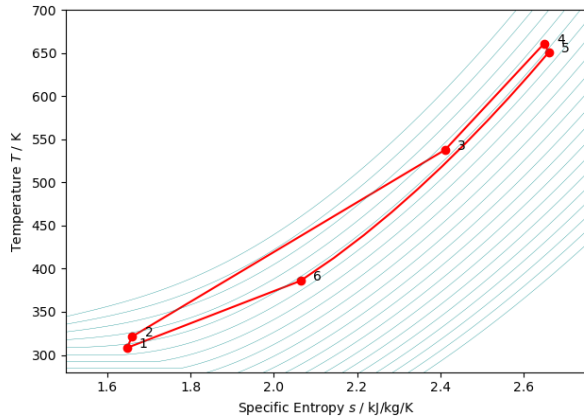

Fig.2 T-S diagram

Table 3. Comparison of cycle parameters

Design parameter	Initial condition	Break-even
Maximum Temperature [°C]	60	363.0
Cycle thermal input [kWth]	32	206.08
Net efficiency [%]	<0	0

2.2 Turbomachinery Design

According to the calculated break-even condition, the components of the cycle were re-designed. The Turbomachinery components consist of compressor and turbine. These turbomachinery components were designed using KAIST-TMD (Turbomachinery Design), an in-house code. The RPM and diameter of compressor and turbine were determined based on the Balje's n_s - d_s diagram under the design inlet and outlet conditions. The compressor and turbine of ABC Test Loop share one shaft in the form of Turbo Alternator Compressor (TAC). In consideration of each optimal RPM, 36000 rpm was selected as the rpm of TAC and designed. The loss model and design parameters were set by referring to existing studies. Figures 3-6 show the efficiency and Pressure Ratio map of compressor and turbine.

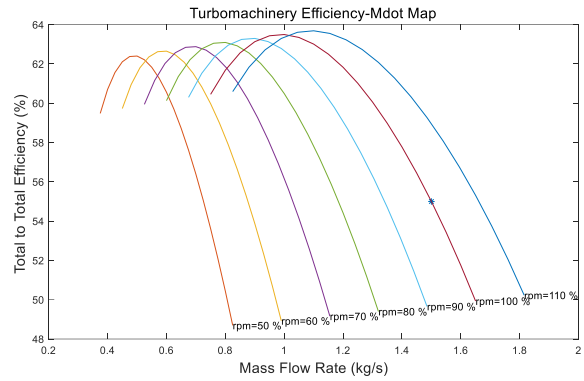

Fig.3 Efficiency map of compressor

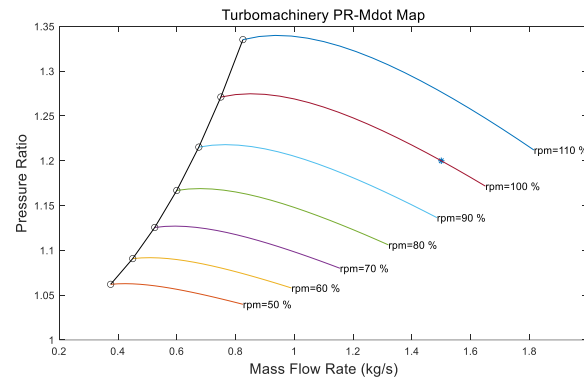

Fig.4 Pressure Ratio map of compressor

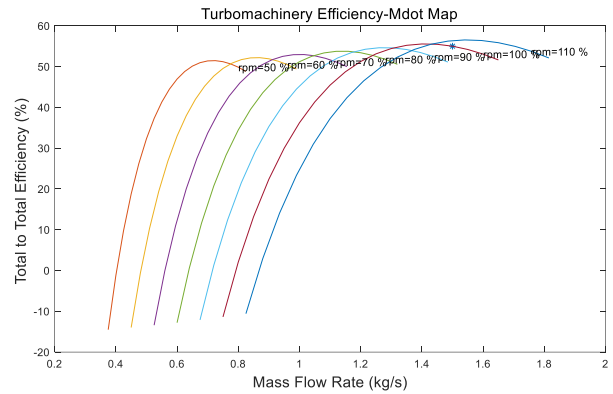

Fig.5 Efficiency map of turbine

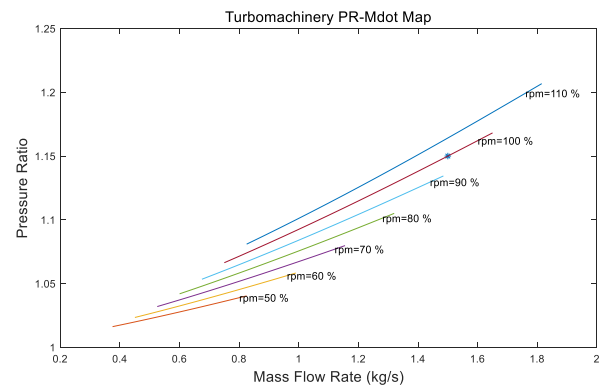

Fig.6 Pressure Ratio map of turbine

2.3 Recuperator Design

The simple recuperated cycle consists of two heat exchangers: pre-cooler and recuperator. In S-CO₂ cycles with high operating pressure, Printed Circuit Heat Exchanger (PCHE) type heat exchangers are preferred due to their high pressure tolerance, compact size and efficient thermal performance [3]. The performance of the recuperator was calculated using KAIST-HXD (Heat exchanger Design), an in-house code for PCHE design [4]. The geometry of the PCHE used in the design is semicircular, as shown in Figure 7.

The recuperator was designed by changing the number and length of channels to meet designed conditions. The inlet and outlet temperatures of each channel were satisfied and the pressure drop did not exceed 100kPa, considering the minor loss. An increase in the number of channels increases the passing area, thereby lowering the pressure drop and increasing the heat transfer. Increase in channel length increases both pressure drop and heat transfer. Table 4 shows the design parameter of recuperator. Figure 8 shows the temperature distribution of the recuperator.

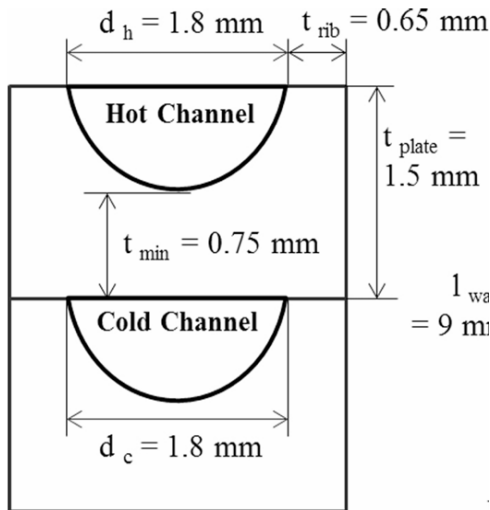

Fig.7 Cross section of PCHE

Table 4. Recuperator design parameter

	Cold channel	Hot channel
No. channel	900	900
Size of channel	1.8mm	1.8mm
Length of channel	0.25m	0.25m
T _{in}	47.17 °C	353.34 °C
T _{out}	303.7 °C	52.7 °C
P _{in}	9.12 MPa	7.8 MPa
P _{out}	9.02 MPa	7.7 MPa
Mass flow	1.5 kg/s	1.5 kg/s
Pressure Drop	45.99 kPa	79.53 kPa
Recuperator		
Effectiveness	0.755	

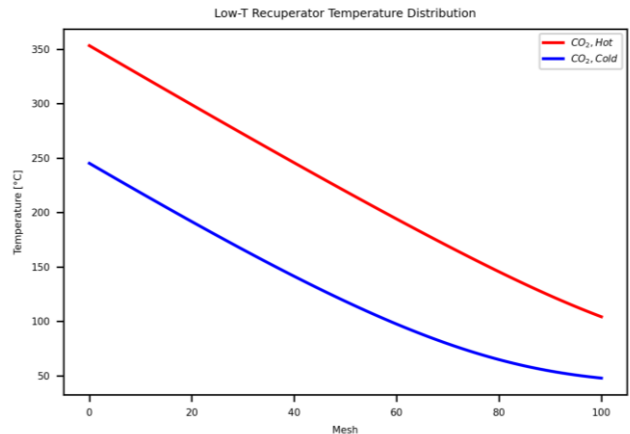

Fig.8 Recuperator Temperature distribution

3. Summary and Future Works

In this research, the break-even operating conditions of the cycle are analyzed for the KAIST test facility. Based on the calculated break-even requirements, the compressor, turbine and recuperator of ABC Test Loop were re-designed to satisfy the new thermodynamic conditions. The analysis shows that achieving break-even requires higher maximum temperature and increased heater output compared to the previous operating conditions. As a result, redesigning major components is essential to ensure stable and continuous cycle operation.

The previous configuration does not satisfy the break-even conditions, which limits the range of obtained data. By re-defining the necessary thermodynamic conditions and reflecting them in component design, this research provides a foundation for achieving break-even conditions.

Overall, this study presents an integrated framework combining break-even analysis and component design, and it offers practical guidelines for future experimental validation and further optimization of the ABC Test Loop.

ACKNOWLEDGEMENT

This work was supported by the National Research Foundation of Korea(NRF) grant funded by the Korea government(MSIT) (No. RS-2025-25454059).

REFERENCES

- [1] Yoonhan Ahn, Seong Jun Bae, Minseok Kim, Seong Kuk Cho, Seungjoon Baik, Jeong Ik Lee, and Jae Eun Cha, Review Of Supercritical CO₂ Power Cycle Technology And Current Status Of Research And Development, Nuclear Engineering and Technology, Vol.47, p.648-650, 2015.
- [2] D. Kim, Y.Jeong, I. W. Son, and J. I. Lee, "Autonomous Brayton Cycle (ABC) Loop with S-CO₂ System Components,"

[3] Johnston, Tony, William Levy, and Svend Rumbold. Application of printed circuit heat exchanger technology within heterogeneous catalytic reactors. American Institute of Chemical Engineers, 2001

[4] S. Baik, S. G. Kim, J. Lee and J. I. Lee, "Validation of Printed Circuit Heat Exchanger Design Code KAIST_HXD," in Transactions of the Korean Nuclear Society Spring Meeting, 2015.