

Design Strategy of an Integrated Safety Protection System with Diverse System for Sodium-cooled Fast Reactor

Kwang Il Jeong*, Dae Il Lee, Hyeong Seok Eun, Joon Ku Lee
Korea Atomic Energy Research Institute, 111, Daedeok-daero 989Beon-gil, Yuseong-gu,
Daejeon

*Corresponding author: hisunny@kaeri.re.kr

***Keywords:** Sodium-cooled fast reactor, reactor protection system, diverse protection system, common cause failure

1. Introduction

The safety of nuclear power plants is ensured by the Reactor Protection System (RPS), which is designed with independence, reliability, redundancy, and diversity. To address Common Cause Failure (CCF) and Anticipated Transients Without Scram (ATWS), regulations require a Diverse Protection System (DPS) that provides independent and diverse protective functions [1,2]. Recent Small Modular Reactor (SMR) designs integrate reactor trip and engineered safety features (ESF) actuation within a unified protection architecture, as seen in NuScale and the Korean innovative SMR (i-SMR), unlike conventional reactors where RPS and ESF actuation systems are separated.

In Sodium-Cooled Fast Reactors (SFRs), the low-pressure pool-type configuration reduces large-break LOCA probability. Thus, protection mainly relies on thermal-hydraulic parameters such as core outlet temperature, primary flow, sodium pool level, and heat removal signals, allowing protection functions to be integrated within a four-channel safety-class structure with sufficient CCF diversity.

2. Related Research and Protection System Architectures

2.1 NuScale Protection System Architecture

NuScale adopts a module-based protection architecture in which reactor trip and ESF actuation functions are integrated within a single protection framework. Four separation groups form four independent channels, while two lower-level divisions perform voting logic for both reactor trip and ESF actuation functions [3]. This integration simplifies system interfaces and improves structural simplicity.

To address diversity requirements, NuScale applies heterogeneous HIPS platforms using two different hardware technologies as indicated in yellow or red colors in Figure 1. By incorporating technological diversity within the protection system, the need for a separate Diverse Protection System (DPS) is eliminated.

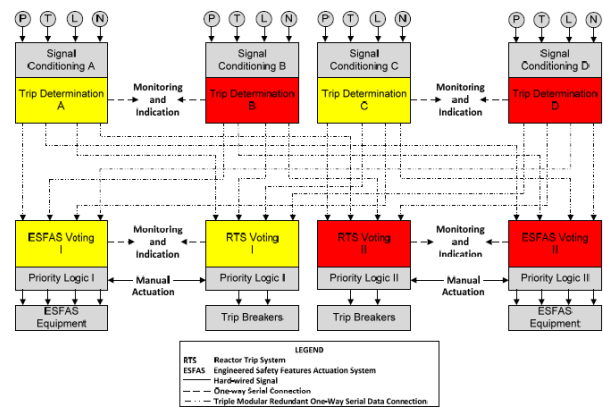

Fig. 1. NuScale Module Protection System Architecture (4 Separation Group)

2.2 Protection System Architecture of Korean i-SMR

The Korean i-SMR maintains redundant safety structures within single channel while integrating reactor trip and ESF actuation logic within the Reactor Safety System (RSS). Compared with conventional large nuclear power plants, the i-SMR design emphasizes modularization and simplification, reducing system complexity while maintaining required safety margins. The RSS is configured as a heterogeneous redundant structure within a single channel, integrating both reactor trip and ESF actuation functions. By utilizing two different hardware platforms (represented in different colors in Figure. 2), the system fulfills diversity requirements and consequently excludes the implementation of a separate DPS [4].

2.3 Comparative Analysis

NuScale and i-SMR share a common architectural trend: the functional integration of reactor trip and ESF actuation mechanisms. This integration reduces internal system interfaces and enhances architectural transparency while maintaining redundancy and diversity.

For SFR, where the number of safety-class actuated components will be relatively reduced and accident progression is dominated by thermal-hydraulic phenomena, a similar integrated structure may provide both technical and economic advantages.

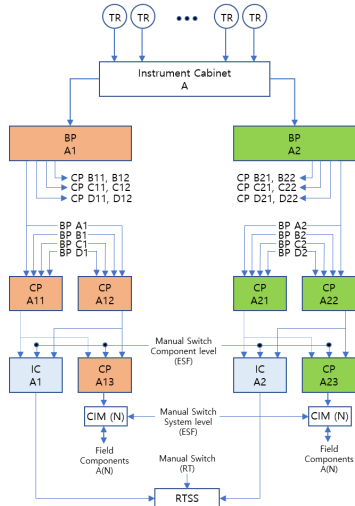

Fig. 2. i-SMR Reactor Safety System Architecture (Ch. A only)

3. Design strategy of ISPS for SFR

3.1 Design Philosophy of ISPS

The proposed Integrated Safety Protection System (ISPS) for SFR adopts a safety-class four-channel architecture that performs both reactor trip and ESF actuation functions within one unified channel. The key design characteristics are as follows:

- Four-channel safety class configuration
- Integration of reactor trip and ESF actuation logic
- Simplified internal interfaces
- Reduced system complexity

Due to the structural characteristics of SFR, including low-pressure operation and natural circulation-based decay heat removal, large-scale active ECCS and complex load sequencing are not required. This enables the protection logic to be implemented in a simplified and unified manner.

3.2 Non-Safety Diverse Protection System (DPS)

To address CCF concerns inherent in a four-channel safety-class architecture, a separate non-safety DPS is introduced. The DPS is designed with the following features:

- Technologically diverse hardware platform from ISPS
- Independent sensing and actuation paths
- Capability to perform reactor trip and ESF actuation functions
- Protection against ATWS and CCF scenarios

This approach provides visible structural diversity while maintaining economic efficiency in the primary safety channel. Figure 3 illustrates the proposed design strategy of ISPS and DPS. The ISPS performs integrated reactor trip and ESF actuation, while the non-safety DPS provides an independent diverse layer capable of initiating reactor trip and ESF actuation(DHRAS) in the event of ISPS CCF.

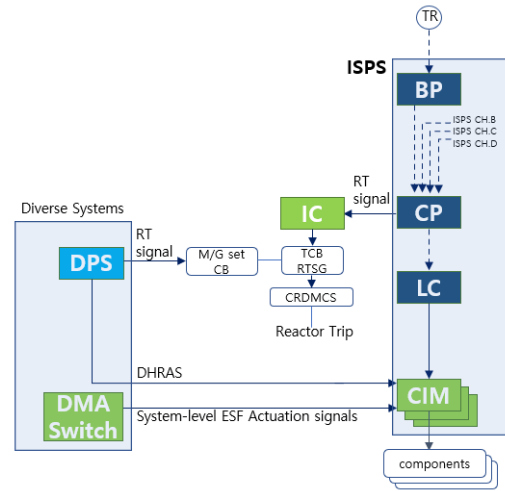

Fig. 3. The architecture of the proposed ISPS (Ch. A only) with non-safety DPS

3.3 Economic and Structural Considerations

The four-channel integrated ISPS architecture offers several potential advantages:

- Reduced number of system interfaces
- Simplified wiring and cabinet configuration
- Lower implementation costs
- Reduced maintenance workload

By minimizing interfaces, the number of potential failure points decreases, leading to improved overall channel reliability. The combination of a simplified safety-class channel and an independent non-safety DPS establishes a balanced structure between economic efficiency and regulatory compliance.

4. Conclusions

This study described the protection system architectures of NuScale and Korean i-SMR and proposed a design strategy of Integrated Safety Protection System (ISPS) for SFR. The proposed structure consists of:

- Safety-class four-channel integrated ISPS performing both reactor trip and ESF actuation functions
- Non-safety class two-channel DPS providing independent and visible diversity against CCF

Considering the structural characteristics of SFR, including low-pressure operation and simplified ESF actuation requirements, the proposed architecture offers technical feasibility, structural simplicity, and economic benefits.

Future work should address detailed component-level control strategies, maintenance interface configurations, manual switch integration, and quantitative reliability assessment in order to further refine and validate the proposed ISPS concept.

ACKNOWLEDGEMENT

This study was supported by the National Research Foundation of Korea(NRF) grant funded by the Korea government(Ministry of Science and ICT)(No. RS-2025-25455699).

REFERENCES

- [1] Nuclear Safety and Security Commission, Regulations on Technical Standards for Reactor Facilities, Article 27, “Diverse Protection System,” 2024.
- [2] NUREG/CR-7007, Diversity Strategies for Nuclear Power Plant Instrumentation and Control Systems, 2009.
- [3] NuScale, FSAR Chapter 7, Instrumentation and Controls.
- [4] K.I. Jeong, J.K. Lee, D.I. Lee, Study on the conceptual design structure of a protection system for small modular reactor, Conference of Korea Society Industrial Information System, Jeju, pp.249-251, 2023.