

# Fine-Tuned Large Language Model for MELCOR No-Coding: the FLAMENCO Project

**Dosu Park<sup>a</sup>**, Kiho Kim<sup>b</sup>, Joongoo Jeon<sup>c\*</sup>, Sooyoung Lee<sup>b\*</sup>

<sup>a</sup> Department of Quantum System Engineering, Jeonbuk National University,

<sup>b</sup> School of Mechanical Engineering, Chung-Ang University, 84 Heukseok-ro, Dongjak-gu, Seoul 06974, Republic of Korea

<sup>c</sup> Division of Advanced Nuclear Engineering, POSTECH





# NINE Lab's Strategy



## TH system code for nuclear reactor (deterministic safety analysis, PSA)

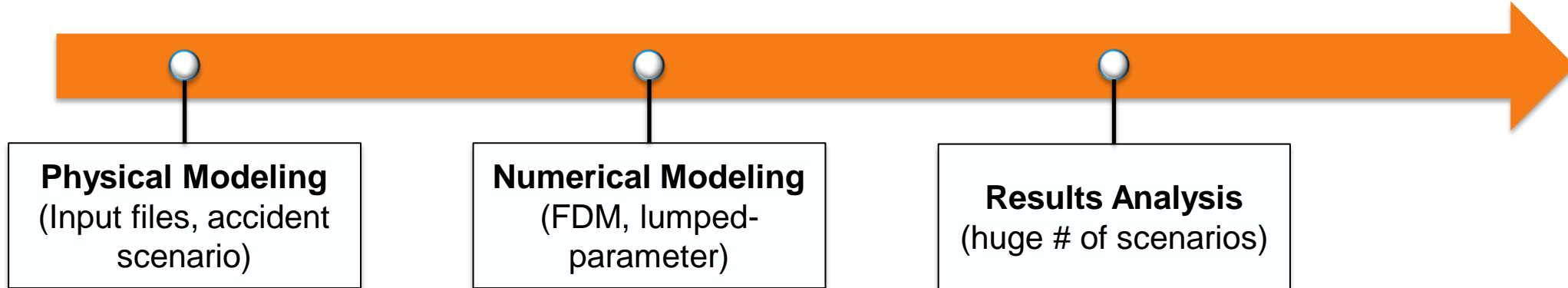

## CFD for nuclear reactor (design, control, etc.)

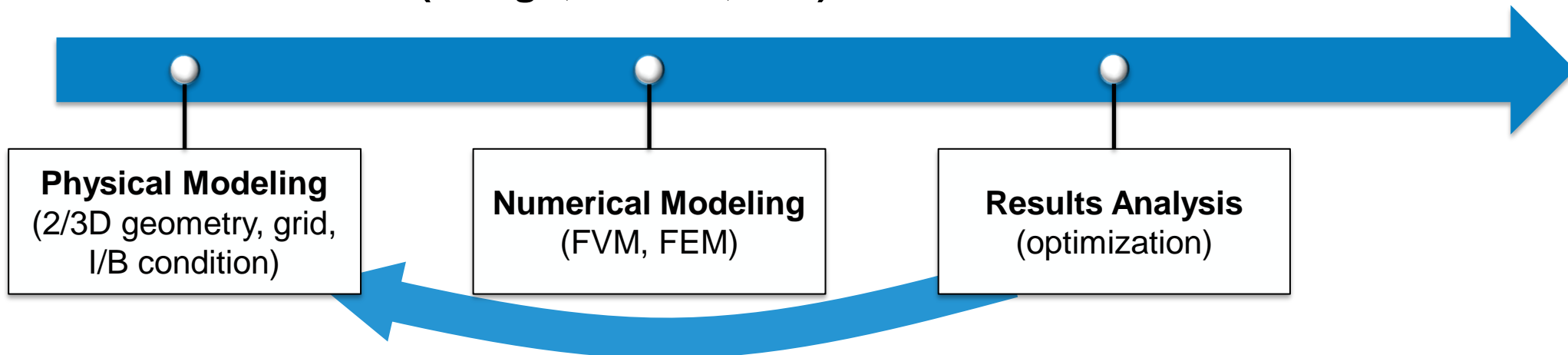

# NINE Lab's Strategy



## TH system code for nuclear reactor (deterministic safety analysis, PSA)

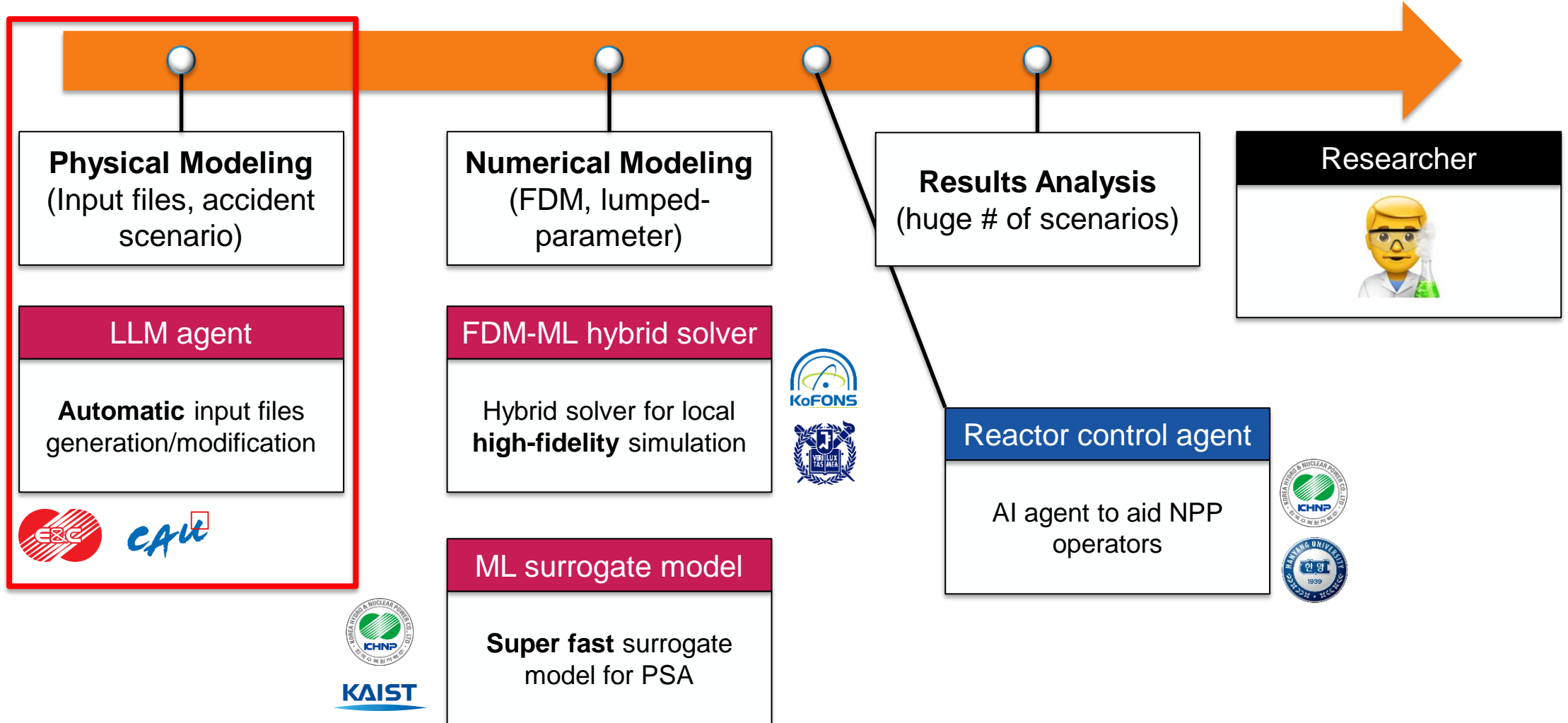

# Overview



**I. Introduction**

**II. Research Motivation**

**III. Methods**

**IV. Results and Analysis**

**V. Conclusions**

# I. Introduction



- **Growing importance of severe accident (SA) analysis**
  - Following the Fukushima Daiichi accident in 2011, the need for preparedness against beyond-design-basis accidents (BDBAs) has been widely emphasized across the international nuclear community.
- **Necessity of integral analysis code**
  - To simulate such severe accidents as a coupled system, integral severe accident codes such as MELCOR and MAAP have been widely adopted.



# II. Research Motivation



- **Limitations of manual input files preparation**

- Manual input files development by experts lead to "User Effect" — missing cards, incorrect values, and inconsistent numbering.

- **Proposed approach: LLM-based automation**

- This study proposes a Large Language Model (LLM)-based framework for automatic generation of MELCOR input files from natural language instructions.

**1 Missing cards**

Required cards are skipped or omitted during manual data entry

```
CV010A1 PVOL 1.01E5
CV010A2 TATM 293.15
[ MLFR.4 card missing ]
† required composition card
CV010BA -30.0 0.0
CV010BB 30.0 10000.0
...
FL01100 CV1-10 001 010
```

→ MELGEN preprocessing failure  
Computation cannot start

**2 Incorrect values**

Wrong numerical values entered due to typos or unit confusion

```
CV010A0 3
CV010A1 PVOL 1.01E5
CV010A2 TATM 2931.5
† typo: should be 293.15 K
CV010A3 MLFR.4 1.0
CV010BA -30.0 0.0
...
FL01100 CV1-10 001 010
```

→ Misleading analysis results  
Run completes, but physics is wrong

**3 Inconsistent numbering**

Identifier or reference mismatches across CV, FL, and HS cards

```
* Defined CVs: 001, 002, ..., 010
CV01000 CV99 2 2 1
CV02000 CV99 2 2 1
...
* Reference in FL card:
FL01100 CV1-99 001 099
† refs CV099 (not defined)
should be 010
```

→ Cross-reference error  
Broken connectivity between cards

# III. Method – General LLM

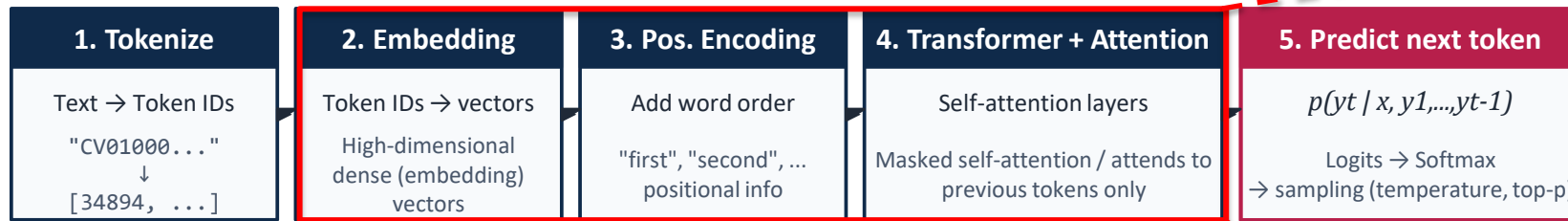

**1 Structural constraint enforcement**

MELCOR has strict format rules:

- Card IDs (CV00100, FL001S1, CF20100)
- Numbering & cross-references

→ Probabilistic generation cannot guarantee them

**2 Domain knowledge gap**

Nuclear simulation data are largely non-public — substantial gap between pretrained knowledge and MELCOR domain.

→ Stable output quality cannot be ensured

## 6. Loop & Decoding (Auto-regressive generation)

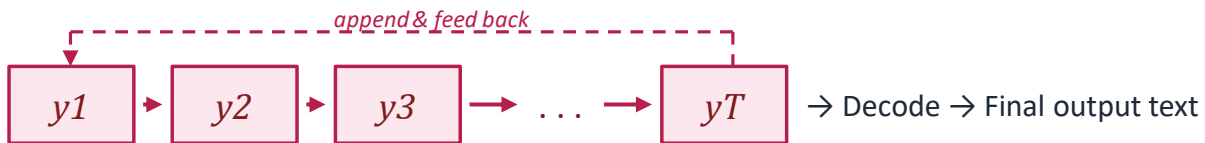

# III. Method – Fine-tuning Method

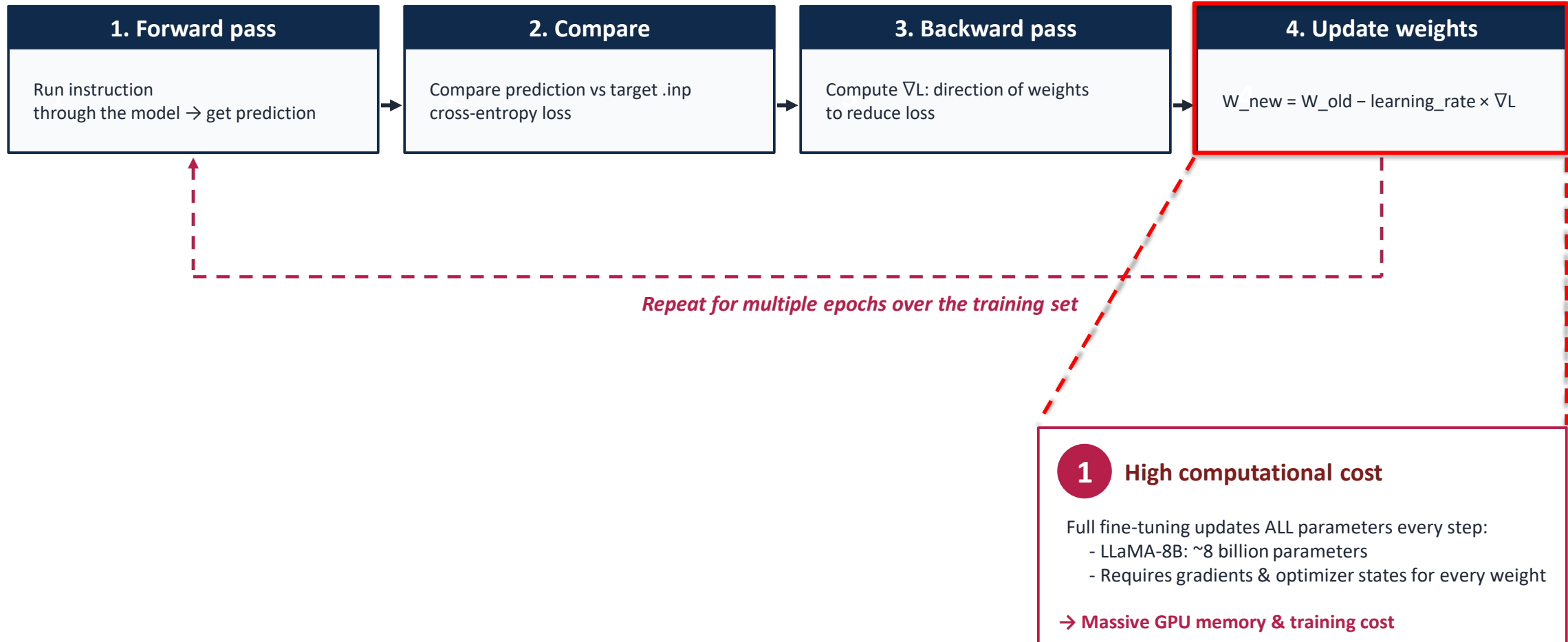

# III. Method - Parameter-Efficient Fine-tuning



- LoRA freezes the pre-trained weights  $W_0$  and trains only the small adapter matrices A and B.
- The learned  $\Delta W = B \cdot A$  is added to  $W_0$ , enabling efficient domain adaptation to MELCOR.

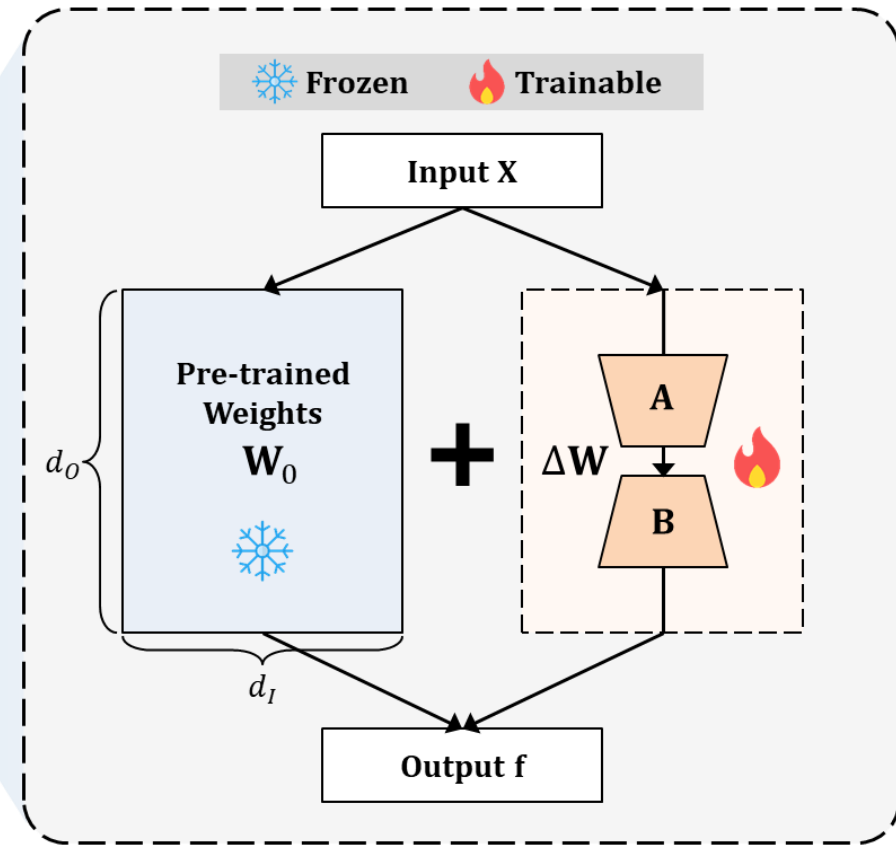
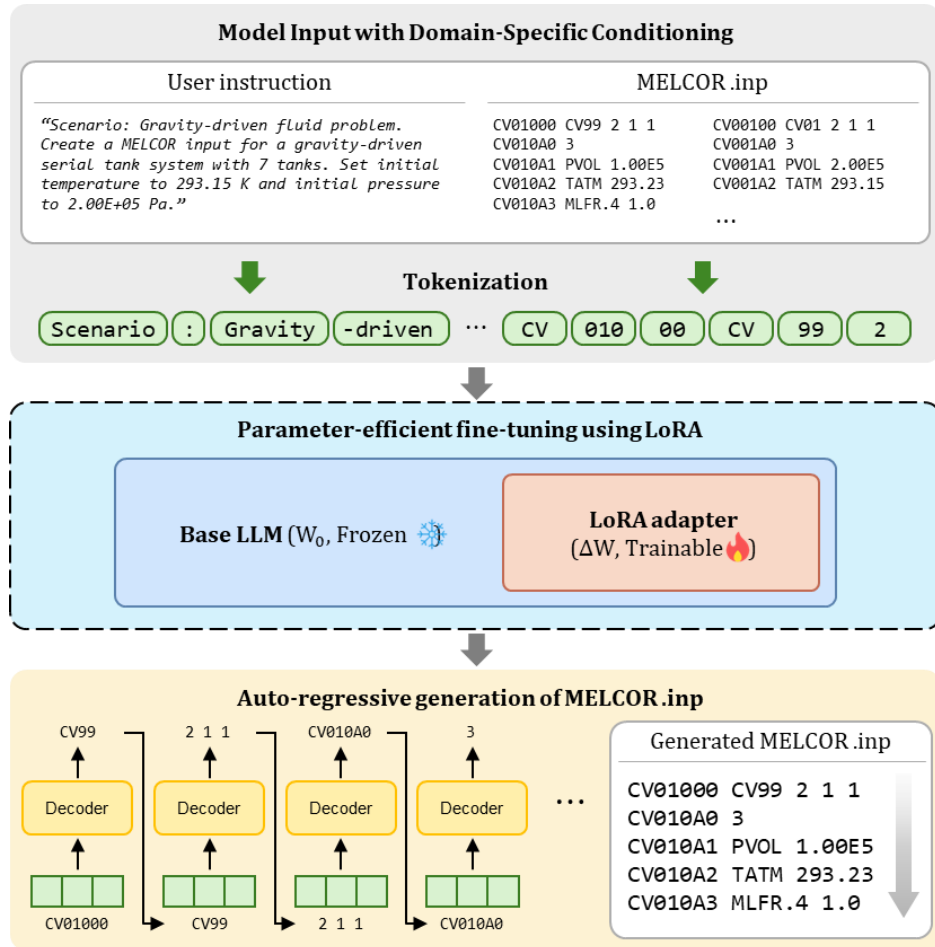

# III. Method - Proposed framework

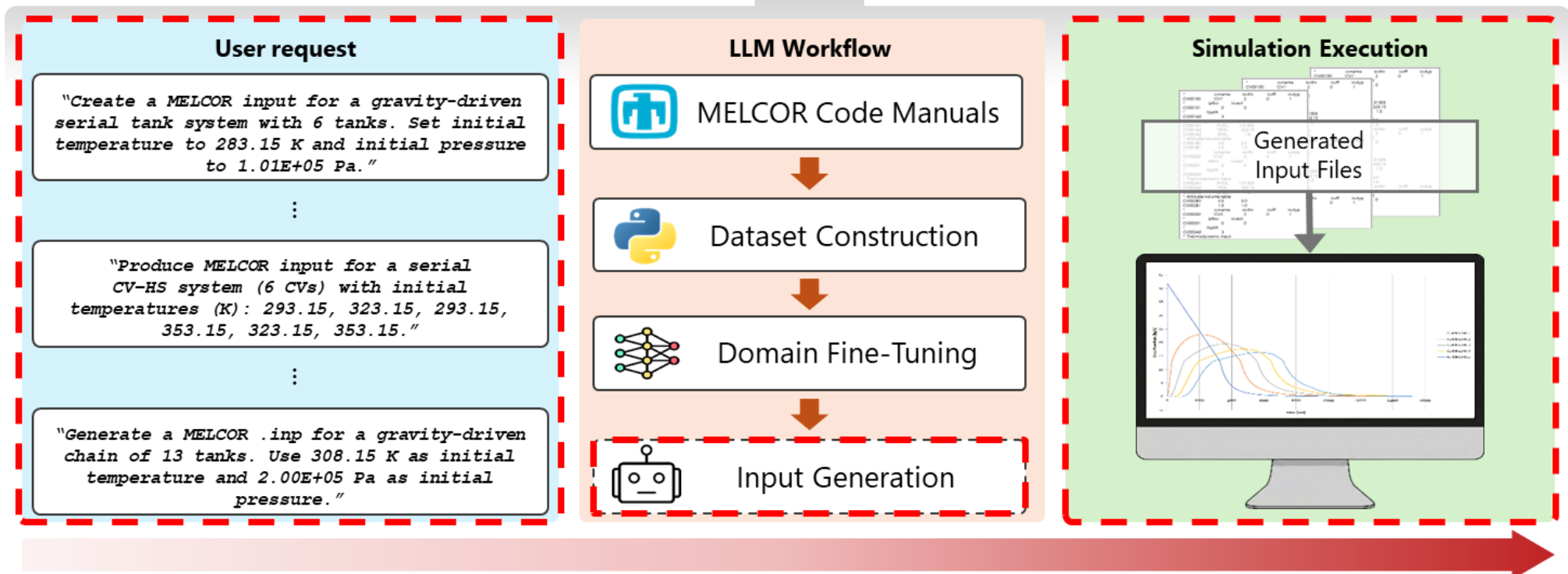
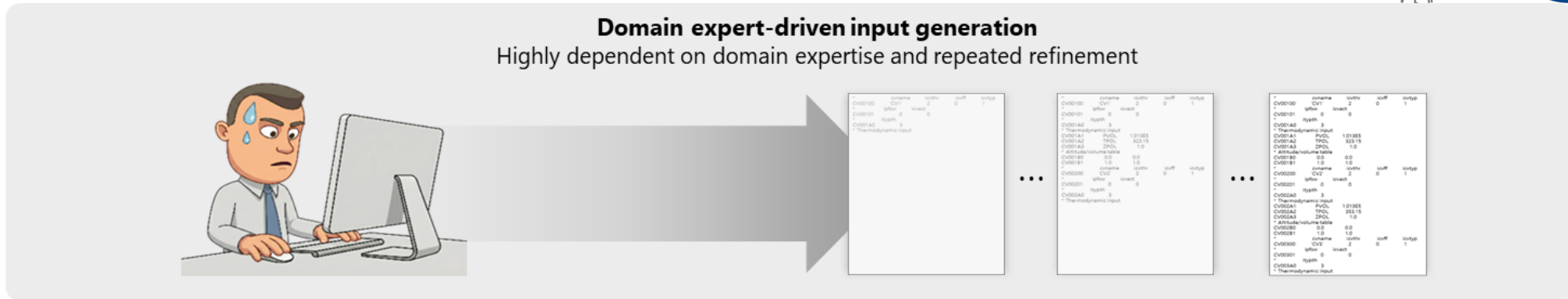

# III. Method - MELCOR Packages and Training Scenarios



- MELCOR consists of multiple physics packages.

➤ To train the LLM on the structural rules of MELCOR input files, two simplified scenarios are adopted in this study.

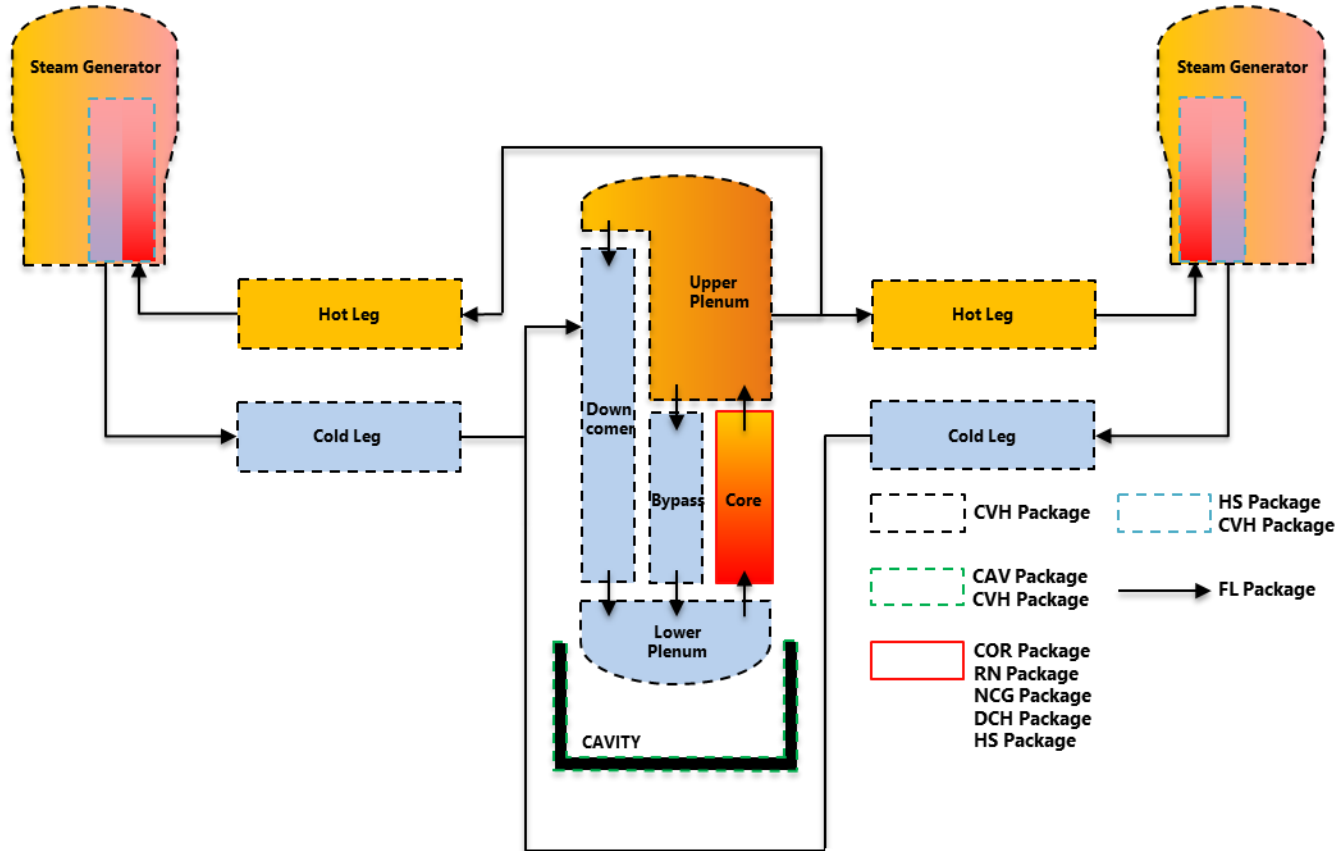

OPR1000 nodalization with the corresponding MELCOR packages

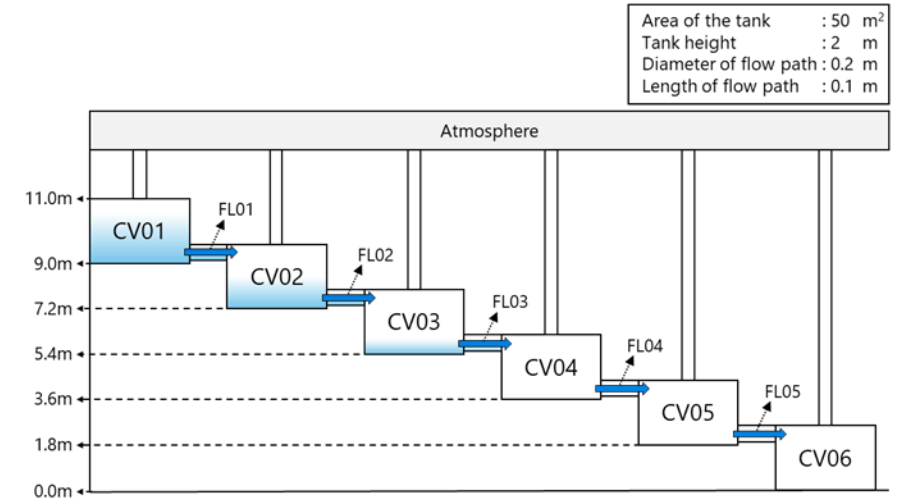

Gravity-driven scenario

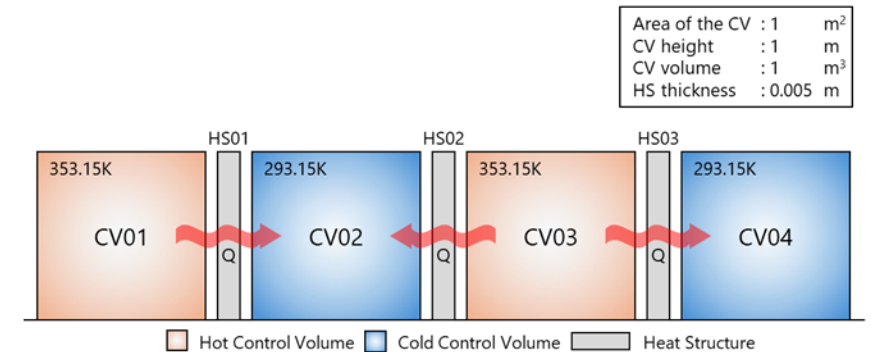

Heat transfer scenario

# III. Method - Training Dataset Construction



- Training data is constructed by pairing executable MELCOR input files with natural language prompts through a three-step pipeline.

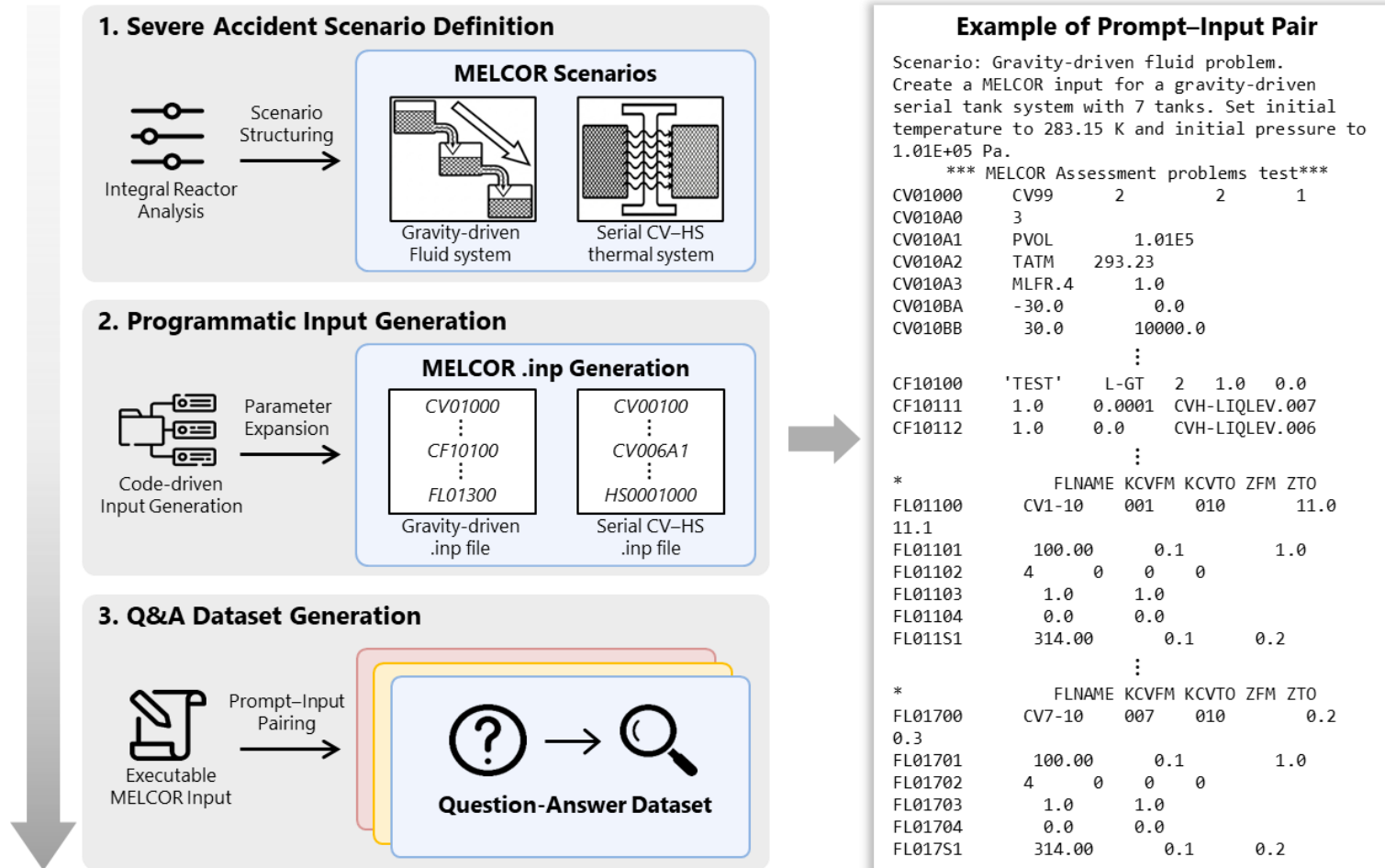

# IV. Results and Analysis - General LLMs vs Fine-tuned



"Scenario: Gravity-driven fluid problem. Create a MELCOR input for a gravity-driven serial tank system with 7 tanks. Set initial temperature to 293.15 K and initial pressure to 2.00E+05 Pa."

GPT 5.2	Gemini 3	Qwen3-8B	Ministral 8B	LLaMA-3-8B
<pre>***** * CONTROL VOLUMES - SERIAL GRAVITY-DRIVEN TANKS ***** CVH100 'Tank 1' VOL=1.0 ZLEV=6.0 P0=2.00E+05 T0=293.15 : CVH700 'Tank 7' VOL=1.0 ZLEV=0.0 P0=2.00E+05 T0=293.15 ***** * FLOW PATHS - SERIAL CONNECTIONS ***** FL101 100 200 A=0.01 L=1.0 K=1.0 GRAV=1 : FL106 600 700 A=0.01 L=1.0 K=1.0 GRAV=1 ***** * INITIAL LIQUID MASS ***** CVH100MASS LIQ=1000.0 CVH200MASS LIQ=1000.0 CVH300MASS LIQ=1000.0 CVH400MASS LIQ=1000.0 CVH500MASS LIQ=1000.0 CVH600MASS LIQ=1000.0 CVH700MASS LIQ=1000.0</pre>	<pre>! === TANK 1 (Top Tank - Source) === CV_ID 'Tank-01' 001 CV_TYPE 'MW' ! Water pool / Water atm CV_PAS POOL ! Start with defined pool CV_VAT 10.0 ! Volume (m3) CV_ELE 70.0 ! Elevation of bottom (m) CV_HGT 5.0 ! Height of CV (m) ! Thermodynamics: P=2.0 bar, T_pool=293.15, T_atm=293.15 CV_THR 1 2.00E+05 293.15 293.15 ! Composition: Full of water (Pool fraction 0.9) CV_Z 1 4.5 ! Pool level at 4.5m (mostly full) : ! === TANK 7 (Bottom Tank - Catch Basin) === CV_ID 'Tank-07' 007 CV_TYPE 'MW' CV_PAS ATM CV_VAT 10.0 CV_ELE 10.0 CV_HGT 5.0 CV_THR 1 2.00E+05 293.15 293.15 : ! Path 1: Tank 1 -&gt; Tank 2 FL_ID 'Flow 1-2' 101 FL_FT 101 001 002 0.0 0.0 ! From 001 To 002 ! Geometry: L=10m (vertical drop), Area=0.1m FL_GEO 101 10.0 0.1 0.0 ! Junction elevation: Bottom of Tank 1 to allow drain FL_JUS 101 70.0 0.0 65.0 0.0 ! Friction/Losses (Open segment) FL_SEG 101 1 10.0 0.1 : ! Path 6: Tank 6 -&gt; Tank 7 FL_ID 'Flow 6-7' 106 FL_FT 106 006 007 0.0 0.0 FL_GEO 106 10.0 0.1 0.0 FL_JUS 106 20.0 0.0 15.0 0.0 FL_SEG 106 1 10.0 0.1</pre>	<pre>CV09900 CV10 2 2 1 CV099A0 3 CV099A1 PVOL 1.01E5 CV099A2 TATM 293.23 CV099A3 MLFR.4 1.0 CV099BA -30.0 0.0 CV099BB 30.0 10000.0 * ICVTYP CV00100 CV01 2 1 1 * ITYPTH CV001A0 3 CV001A1 TPOL 293.15 CV001A2 PVOL 2.00E5 CV001A3 VPOL 100.00 CV001BA 9.0 0.0 CV001BB 11.0 100.0 : * CF10100 'TEST' L-GT 2 1.0 0.0 CF101A1 1.0 0.0001 CVH-LIQLEV.007 CF101A2 1.0 0.0 CVH-LIQLEV.006 : * FLNAME KCVFM KCVTO ZFM ZTO FL10100 CV1-99 001 010 11.0 11.1 FL10101 100.00 0.1 1.0 FL10102 4 0 0 0 FL10103 1.0 1.0 FL10104 0.0 0.0 FL101S1 314.00 0.1 0.2 : * FLNAME KCVFM KCVTO ZFM ZTO FL10700 CV7-99 007 010 0.2 0.3 FL10701 100.00 0.1 1.0 FL10702 4 0 0 0 FL10703 1.0 1.0 FL10704 0.0 0.0 FL107S1 314.00 0.1 0.2</pre>	<pre>CV09900 CV10 2 2 1 CV099A0 3 CV099A1 PVOL 1.01E5 CV099A2 TATM 293.23 CV099A3 MLFR.4 1.0 CV099BA -30.0 0.0 CV099BB 30.0 10000.0 * ICVTYP CV00100 CV01 2 1 1 * ITYPTH CV001A0 3 CV001A1 TPOL 293.15 CV001A2 PVOL 2.00E5 CV001A3 VPOL 100.00 CV001BA 9.0 0.0 CV001BB 11.0 100.0 : * CF10100 'TEST' L-GT 2 1.0 0.0 CF10111 1.0 0.0001 CVH-LIQLEV.007 CF10112 1.0 0.0 CVH-LIQLEV.006 : * FLNAME KCVFM KCVTO ZFM ZTO FL10100 CV1-99 001 010 11.0 11.1 FL10101 100.00 0.1 1.0 FL10102 4 0 0 0 FL10103 1.0 1.0 FL10104 0.0 0.0 FL101S1 314.00 0.1 0.2 : * FLNAME KCVFM KCVTO ZFM ZTO FL10700 CV7-99 007 010 0.2 0.3 FL10701 100.00 0.1 1.0 FL10702 4 0 0 0 FL10703 1.0 1.0 FL10704 0.0 0.0 FL107S1 314.00 0.1 0.2</pre>	<pre>CV09900 CV10 2 2 1 CV099A0 3 CV099A1 PVOL 1.01E5 CV099A2 TATM 293.23 CV099A3 MLFR.4 1.0 CV099BA -30.0 0.0 CV099BB 30.0 10000.0 * ICVTYP CV00100 CV01 2 1 1 * ITYPTH CV001A0 3 CV001A1 TPOL 293.15 CV001A2 PVOL 2.00E5 CV001A3 VPOL 100.00 CV001BA 9.0 0.0 CV001BB 11.0 100.0 : * CF10100 'TEST' L-GT 2 1.0 0.0 CF10111 1.0 0.0001 CVH-LIQLEV.007 CF10112 1.0 0.0 CVH-LIQLEV.006 : * FLNAME KCVFM KCVTO ZFM ZTO FL10100 CV1-99 001 010 11.0 11.1 FL10101 100.00 0.1 1.0 FL10102 4 0 0 0 FL10103 1.0 1.0 FL10104 0.0 0.0 FL101S1 314.00 0.1 0.2 : * FLNAME KCVFM KCVTO ZFM ZTO FL10700 CV7-99 007 010 0.2 0.3 FL10701 100.00 0.1 1.0 FL10702 4 0 0 0 FL10703 1.0 1.0 FL10704 0.0 0.0 FL107S1 314.00 0.1 0.2</pre>
<p>Tank count <span style="color: green;">●</span></p> <p>Connection correctness <span style="color: red;">✘</span></p> <p>Input executability <span style="color: red;">✘</span></p> <p>Requirement satisfaction <span style="color: red;">✘</span></p>	<p>Tank count <span style="color: green;">●</span></p> <p>Connection correctness <span style="color: red;">✘</span></p> <p>Input executability <span style="color: red;">✘</span></p> <p>Requirement satisfaction <span style="color: red;">✘</span></p>	<p>Tank count <span style="color: green;">●</span></p> <p>Connection correctness <span style="color: green;">●</span></p> <p>Input executability <span style="color: red;">✘</span></p> <p>Requirement satisfaction <span style="color: green;">●</span></p>	<p>Tank count <span style="color: green;">●</span></p> <p>Connection correctness <span style="color: green;">●</span></p> <p>Input executability <span style="color: green;">●</span></p> <p>Requirement satisfaction <span style="color: green;">●</span></p>	<p>Tank count <span style="color: green;">●</span></p> <p>Connection correctness <span style="color: green;">●</span></p> <p>Input executability <span style="color: green;">●</span></p> <p>Requirement satisfaction <span style="color: green;">●</span></p>

# IV. Results and Analysis - Error Distribution



- Quantitative analysis of structural errors across models.
- LLaMA-3-8B achieves the lowest error level, maintaining the input structure most stably.

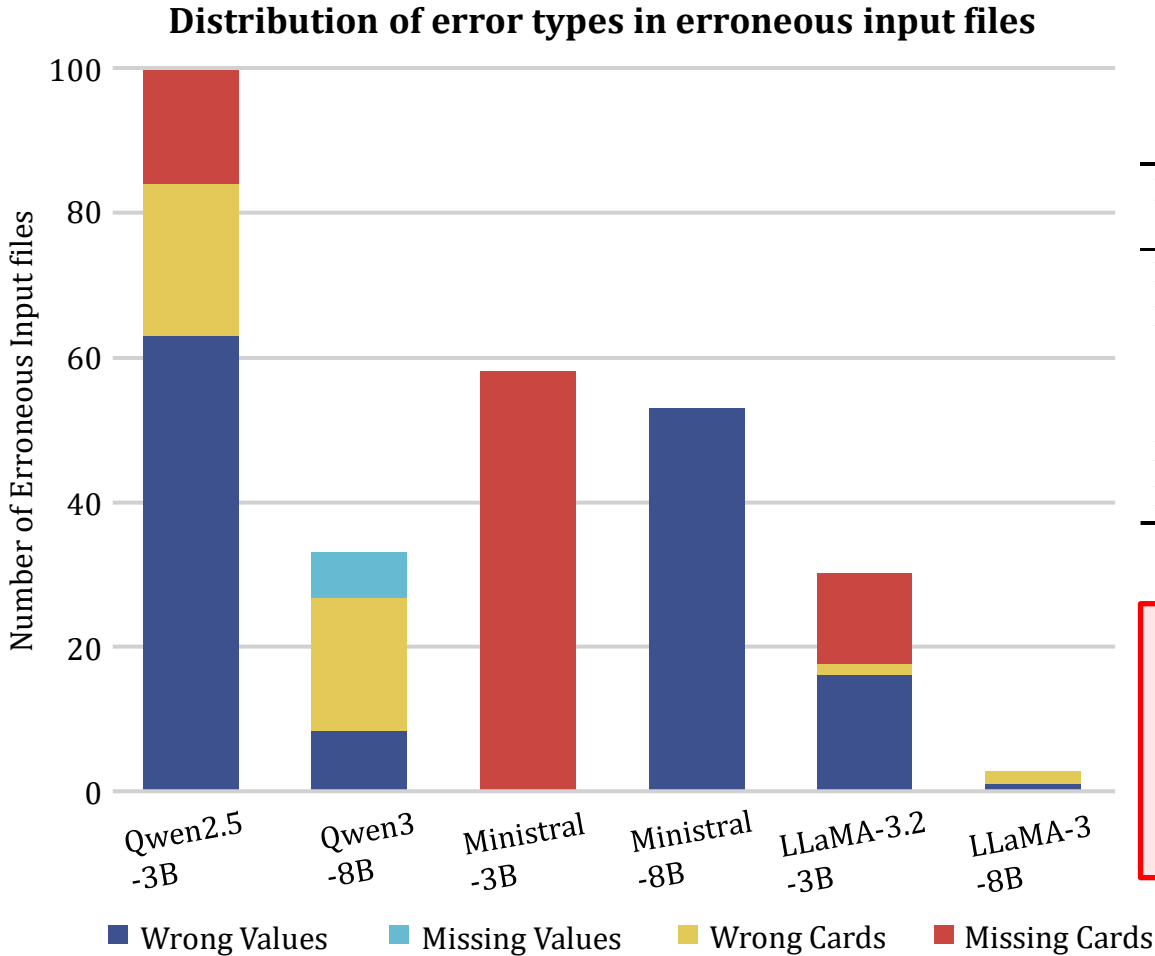

\* Fragmentation ratio: how finely a tokenizer splits a string

Model	Tokenized output	Fragmentation ratio
LLaMA-3.2-3B	'CV' 'H' '-L' 'IQ' 'LEV' '.' '007'	0.40
LLaMA-3-8B	'CV' 'H' '-L' 'IQ' 'LEV' '.' '007'	0.40
Qwen2.5-3B	'CV' 'H' '-L' 'IQ' 'LEV' '.' '0' '0' '7'	0.56
Qwen3-8B	'CV' 'H' '-L' 'IQ' 'LEV' '.' '0' '0' '7'	0.56
Ministral-3B	'_CV' 'H' '-' 'LI' 'Q' 'LE' 'V' '.' '0' '0' '7'	0.63
Ministral-8B	'CV' 'H' '-L' 'I' 'Q' 'LE' 'V' '.' '0' '0' '7'	0.66

Tokenization of the MELCOR input string "CVH-LIQLEV.007" across models.

1. Tokenization
  - Lower fragmentation preserves semantic units better
2. Model scale
  - Larger models perform better

# IV. Results and Analysis - Executability ≠ Correctness



- Executable success rate alone does not guarantee structural correctness
  - **Ministral-8B achieves 100% executability but 58/100 contain errors.**

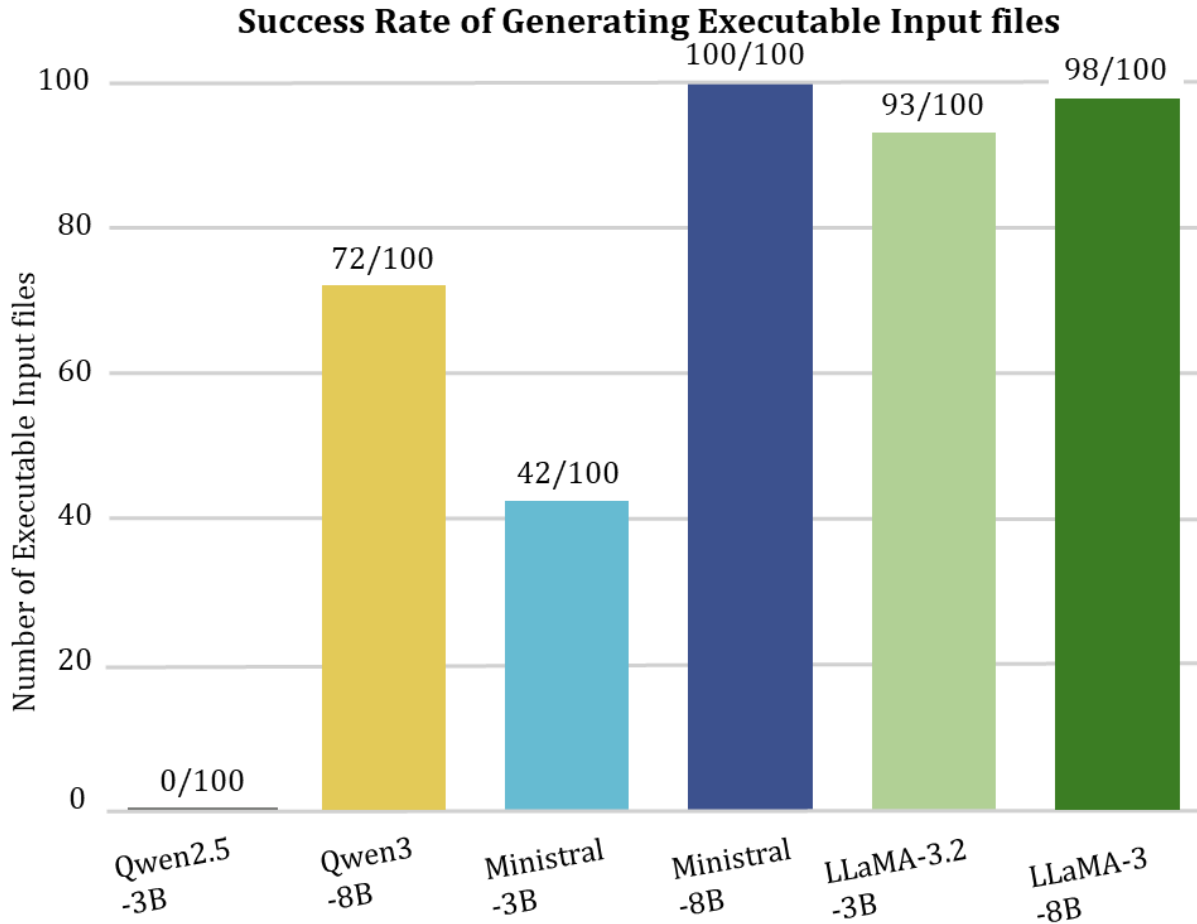

Model	Missing FL card rate (%)	Incorrect FL value rate (%)	Incorrect CF index rate (%)
Qwen2.5-3B	N/A	N/A	N/A
Qwen3-8B	0	0	0
Ministral-3B	0	0	0
Ministral-8B	0	0	53.0
LLaMA-3.2-3B	5.7	15.7	0
LLaMA-3-8B	0	0	1.0

Remaining error rates within executable input files.

# IV. Results and Analysis - Executable but contain errors



- Even when MELCOR completes execution without errors, structural defects in input files lead to physically invalid results.

(a) Wrong values

"Create a MELCOR input for a gravity-driven serial tank system with 17 tanks. Set initial temperature to 288.15 K and initial pressure to 1.50E+05 Pa."

```
*
  FLNAME KCVFM KCVTO ZFM ZTO
FL00700  CV7-8  007  008  -1.6  -1.6
* FL GEOM  AREA LENGTH  FRACTION OPEN
FL00701  0.03  0.5  1.0
* FL JUNC  KFLGFL TYPE OF FLOW PATH FLAG : 3
= NORMAL HORIZONTAL FL
FL00702  3  0  0  0
* FL LOSS COEFFFL00703  20.0  20.0
* INITIAL ATM AND POOL VEL
FL00704  0.0  0.0
* PIPING SEGMENT PARAM
* FLOW A  SLEN  SHYD
FL007S1  0.03  0.1  0.2
*
  FLNAME KCVFM KCVTO ZFM ZTO
FL00800  CV8-9  008  009  -3.4  -3.4
* FL GEOM  AREA LENGTH  FRACTION OPEN
FL00801  0.03  0.5  1.0
* FL JUNC  KFLGFL TYPE OF FLOW PATH FLAG : 3
= NORMAL HORIZONTAL FL
FL00802  3  0  0  0
```

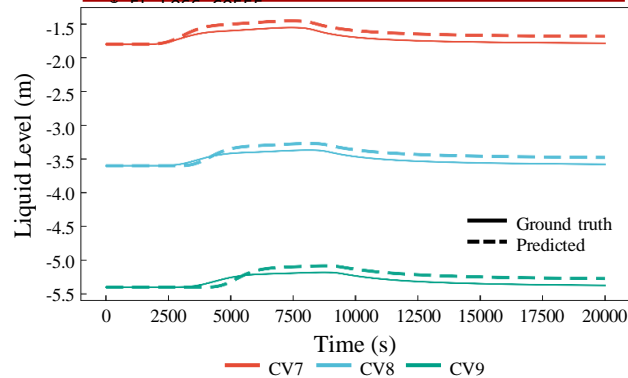

(b) Missing cards

"Build a gravity-driven MELCOR input. Tanks: 19. Initial temperature: 293.15 K. Initial pressure: 1.01E+05 Pa. Output MELCOR .inp text only (no explanations)."

```
FL118S1  314.00  0.1  0.2
*
  FLNAME KCVFM KCVTO ZFM ZTO
FL11900  CV19-99  019  099  -21.4  -
21.3
FL11901  100.00  0.1  1.0
FL11902  4  0  0  0
FL11903  1.0  1.0
FL11904  0.0  0.0
FL119S1  314.00  0.1  0.2
*
*
* PRED_END
* *****<<<<FL from CV1 to CV2>>>>*****
*
  FLNAME KCVFM KCVTO ZFM ZTO
FL00100  CV1-2  001  002  9.1  9.1
* FL GEOM  AREA LENGTH  FRACTION OPEN
FL00101  0.03  0.5  1.0
* FL JUNC  KFLGFL TYPE OF FLOW PATH FLAG : 3
= NORMAL HORIZONTAL FL
```

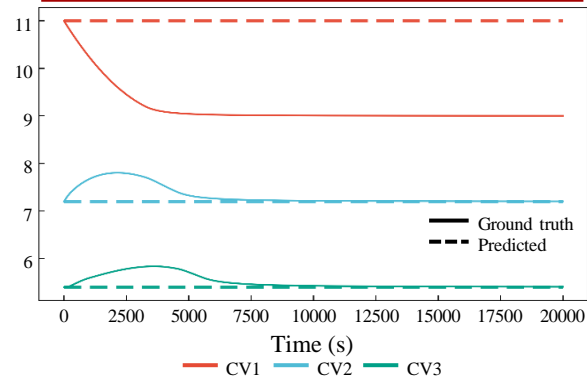

(c) Ground truth

"Produce MELCOR input (gravity-driven, 6 tanks). Initialize temperature = 293.15 K and pressure = 1.01E+05 Pa. Respond with .inp text only."

```
*
  NAME SWITCH FLOW-FLAG
ICVTYP
CV00100  CV01  2  1  1
*
  ITYPH
CV001A0  3
CV001A1  TPOL  293.15
CV001A2  PVOL  1.01E5
CV001A3  VPOL  100.00
CV001BA  9.0  0.0
CV001BB  11.0  100.0
*
  FLNAME KCVFM KCVTO ZFM ZTO
FL10100  CV1-99  001  099  11.0
11.1
FL10101  100.00  0.1  1.0
FL10102  4  0  0  0
FL10103  1.0  1.0
FL10104  0.0  0.0
FL101S1  314.00  0.1  0.2
*
  FLNAME KCVFM KCVTO ZFM ZTO
FL00100  CV1-2  001  002  9.1
```

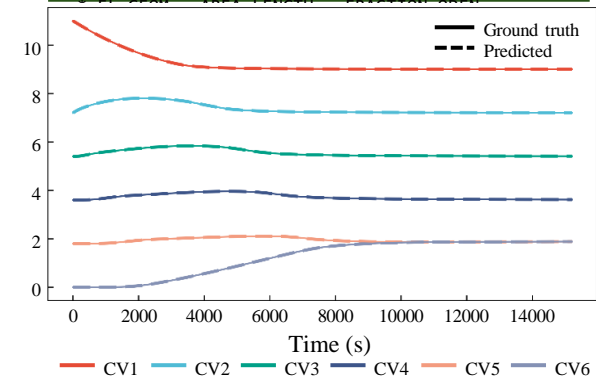

# V. Conclusions



## Summary

- Proposed an LLM-driven framework for automatic generation of MELCOR input files from natural language instructions.
- Domain adaptation via LoRA-based PEFT enables efficient fine-tuning of 8B-scale models.
- LLaMA-3-8B achieves the lowest structural error rate (2/100), showing the impact of tokenizer fragmentation and pretrained model selection
- Executability  $\neq$  Correctness — Ministral-8B reaches 100% executability but 58/100 contain errors, highlighting the need for input integrity validation.

## Future work

- MELCOR-optimized tokenization based on LLaMA-3 to find the best fragmentation ratio for MELCOR domain.
- Extension to actual SMR input files data.
- Multi-agent verification (Generator–Executor–Discriminator) for hallucination detection and mitigation

# Acknowledgment



This study was supported by KEPCO Engineering & Construction Company and Chung-Ang University.



**한국전력기술**  
KEPCO ENGINEERING & CONSTRUCTION

# Thank You. Any Questions?

Dosu Park\*

Undergraduate Internship NINE Lab.

Department of Quantum System Engineering, Jeonbuk National University

[ehtnqkr@jbnu.ac.kr](mailto:ehtnqkr@jbnu.ac.kr)