

Blind-Benchmark Calculation of an Erosion of Helium Stratified Layer Test: H2P1_10_2 on the OECD/NEA HYMERES-2 Project

Hyoungh Tae Kim^{a*} and Jongtae Kim^a
Se-Myong Chang^b

^a Accident Monitoring and Mitigation Research Team, KAERI, Daeduk-daero 989-111, Daejeon, Korea

^b Kunsan National University, 558 Daehak-ro, Gunsan, Korea, Korea

*Corresponding author: kht@kaeri.re.kr

1. Introduction

In the frame of the OECD/NEA HYMERES (HYdrogen Mitigation Experiments for REactor Safety) Phase 2 project [1], six test series for a total of 24 experiments have been and planned to be conducted in the PANDA facility [2] at the Paul Scherrer Institut (PSI), Switzerland. The HYMERES-2 project program has its general objective to advance the knowledge on the containment thermal-hydraulics.

Among the test series by HYMERES-2 project, the H2P1 series deal with the jet/plume interacting with various complex obstruction geometries, which are resembling those of nuclear containment internal structures. One of the H2P1 series, the H2P1_10_2 test [3] was chosen for blind-benchmark of CFD (Computational Fluid Dynamic) codes through participation in the HYMERES-2 project.

The experiment for this benchmarking calculation deals with stratified erosion of test vessel initially filled with a mixture of vapor and helium (hydrogen simulations) in the upper area and the remaining volume of the vessel filled with steam [4]. The main simulation in CFD calculations is to predict the process of vertical steam jets from the outlet of circular pipes located below a helium-rich layer, interacting with them as they go through a structure with a sloping grid shape in the middle, and then eroding the upper vapor and helium mixture layer. To this end, a mesh generation for complex-shaped sloped grid structures and surrounding test vessel was properly conducted using block mesh of a ANSYS ICEM CFD [5] tool. The erosion of helium stratified layers over time was visualized as a result of CFD code calculations, for the given test boundary conditions. Later, the results of this CFD calculation will be compared with test data, when the data of H2P1_10_2 test is disclosed for open-benchmark calculation.

2. Test Description

2.1 Facility configuration of H2P1_10_2

The test H2P1_10_2 [3] is focused on the helium-rich layer erosion and overall fluid transport and mixing in vessel 1 (as shown in Fig. 1) of the PANDA facility for two-gases, for fluid conditions without condensation and under constant pressure, by a vertical steam jet which is obstructed by an inclined grid located in the path of the jet. The experimental volume consists of two large

cylindrical vessels (vessels 1 and 2) of an inner height of 8 m and having an inner volume of 89.9 m³. Each of the two vessels is manufactured of four components (top and bottom cap and two cylindrical components) made of stainless steel with outer diameter of 4 m.

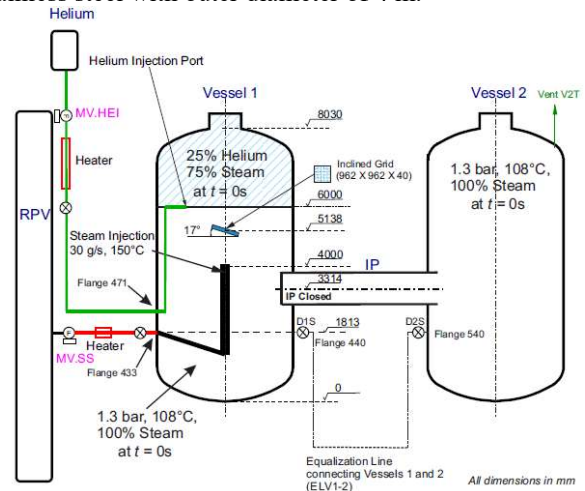

Fig. 1. Test configuration and nominal initial conditions [3].

2.2 Test conditions

Table 1 shows the nominal initial conditions for the test H2P1_10_2, which are 100% steam environment at 1.3 bar with gas and wall temperatures of 108 °C in vessels 1 and 2 of the PANDA facility. A layer of 25% molar helium-75% molar steam is created in the vessel 1 from 6 m above the bottom to the top of the vessel 1.

Table 1: Test conditions of H2P1_10_2

Component	Nominal Condition
Initial gas composition	100 % steam
Initial wall temperature	108 °C
Initial pressure	1.3 bar
Steam inj. temperature	150 °C
Steam mass flow rate	30 g/s
Injection pipe diameter	200 mm
Helium content in layer	25 %

The inter-connecting tube (IP) between the vessels 1 and 2 is closed with a lid on the side of vessel 1 in order to block the flow through the IP. The pressure is equalized between the two vessels by connecting them

by an equalization line. Superheated steam at 150 °C is injected during the main phase of the test, with a flow rate of 30 g/s, through a tube with 0.2 m internal diameter, in vertical direction towards the helium layer. An inclined grid (17° inclination) is located co-axially in the path of the jet at the level of 5.138 m, above the injection tube exit. The pressure in the vessels 1 and 2 is 1.3 bar and kept constant during the test, by venting from a location in the top region of Vessel 2. The vessel wall temperatures, the gas temperatures and the gas concentrations in the vessel 1 are measured throughout the test.

2.3 Test procedures

The test procedure consisted of pre-conditioning the facility to realize the initial conditions, where Helium-rich layer is created in the vessel 1 above 6 m. This was followed by the main test phase, where superheated steam at 150°C was injected at 30 g/s.

3. CFD Modeling

3.1 CFD tools used

Two kinds of the CFD codes, ANSYS CFX version 17.0 [6] and OpenFOAM version 7 [7] are used to simulate the benchmark test, which are commercial one and free software, respectively.

SST turbulence model with buoyancy generation and dissipation is used for these two codes.

3.2 Geometry

The computational domain includes only the vessel 1 with full representation of the 3-dimensional geometry. Since the venting line from vessel 1 to vessel 2 through a pressure equalization line is located at 1813 mm from the bottom of the vessel, the entrance area on the surface of vessel is modeled as outlet of fluid.

The upper man-hole and the upper, straight section of the injection pipe is represented. The steam injection pipe is supposed to be only a hydraulic obstruction and not to participate in heat transfer processes.

3.2 Initial conditions

Velocities and turbulence are set to zero at $t=0.0$ second. The actual measured distributions of gas temperature and concentrations specified in the report [3] are prescribed as close as possible.

For the wall temperature of the man-hole lid a value of 101°C is prescribed, whereas for all other surfaces (including the grid) a value of 108 °C is used.

3.3 Boundary conditions

The smoothed pressure values in the vessel, which are provide for blind-benchmark calculation, are used for

outlet pressure conditions: for the first 1000 seconds, and the also provided average value for the later times (up to 3000 seconds).

Injected steam mass flow rate is provided by the smoothed values for the first 1000 seconds, and an average value for the later times (up to 3000 seconds).

Injected steam temperature is prescribed using the provided values for 3000 seconds.

The wall temperatures are prescribed as follows:

- Man hole lid: constant value at 101 °C
- Man hole cylindrical wall: decreasing from initial value (108 °C) at a rate of $\sim 0.12\text{K}/100\text{ s}$
- All other vessel walls: constant at 108 °C

3.4 Radiation heat transfer model

P1 radiation heat transfer model with a steam absorptivity coefficient of 1/m is used.

3.5 Mesh generation

A block structured base mesh is generated with ANSYS ICEM CFD. Fig. 2 shows the mesh generation results for vessel and grid section, respectively.

Since cells are accumulated in the center blocks, the block structured meshing with O-grid is beneficial to adopt the majority of the flow gradients within the center part of the vessel. It could be also coarsened easily to $\sim 2,000,000$ nodes by reducing circumferential number of cells around the resolved mesh in the grid plate as shown in Fig. 2 (b). O-grid allows to resolve flow with 10 nodes per channel (resolved mesh refinements), but only 2x2 attached cells per channel.

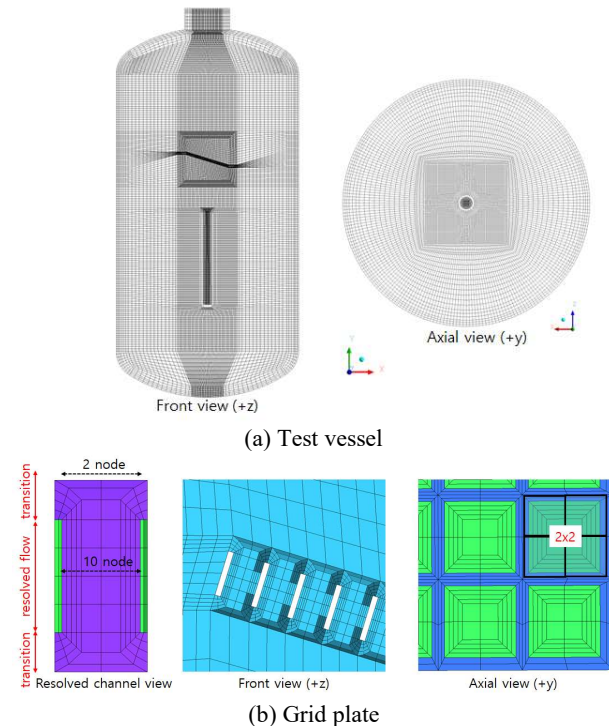

Fig. 2. Mesh generation for the H2P1_10_2 benchmark calculation.

4. Blind Calculation Results

The participants in the blind benchmark are expected to provide numerical data for a number of selected variables: most of them are variation of time with gas concentration (mole fraction of helium), gas temperature, and grid wall temperature, which will be compared with the experimental results. The measurement locations where the calculation results to be obtained are shown in Fig. 3.

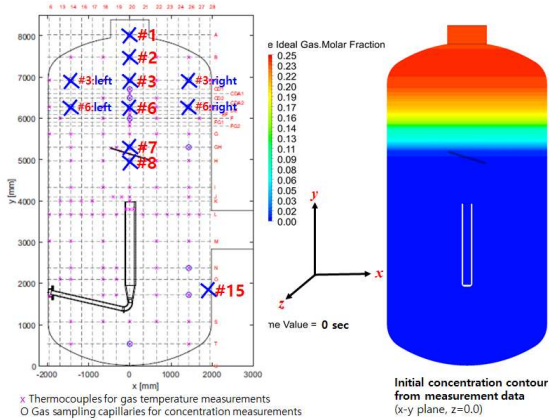
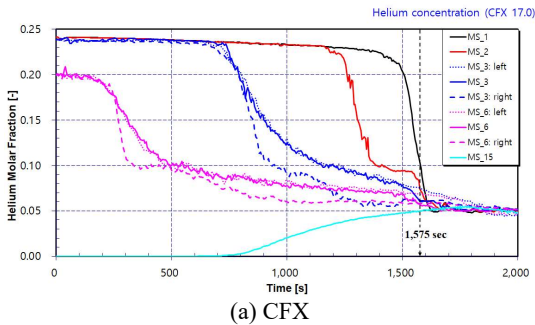

Fig. 3. Location of thermocouple and capillaries for measurements of gas temperature and concentration, respectively [3].

4.1 Erosion of helium stratified layer

The helium concentration evolution for selected measurements of the vessel 1 are presented in Fig. 4. The CFX code predicts that helium concentration on the axis at $y=8,030$ mm (black line of position #1 in the Fig. 4-a) drops below 10% at 1,575 sec of simulation time.



(a) CFX

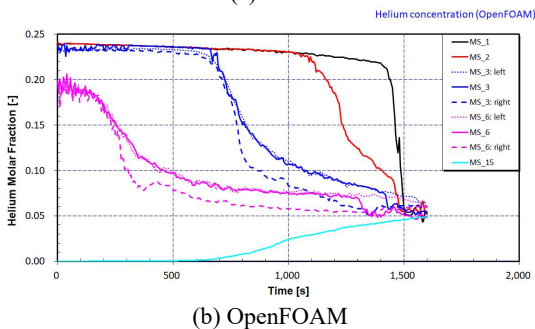

(b) OpenFOAM

Fig. 4. Helium molar fraction evolution in the vessel.

4.2 Gas temperature

Fig. 5 shows the gas temperature evolution along various vertical measurement points. Most of the gas temperature is lower than the injection temperature ($\sim 150^\circ\text{C}$) with a heat loss to the cold vessel wall (constant temperature of 108°C) by convective and radiation heat transfer processes. Since the gas temperature at the highest measured point (at $y=8,030$ mm) is most far from the steam injection point, it is lower than other temperatures at lower elevation points. However, this temperature (TC_1) rapidly increases to more than 110°C , when the helium concentration drops below 0.1 (1,575 sec) and the steam jet reaches this point (Fig. 5-a).

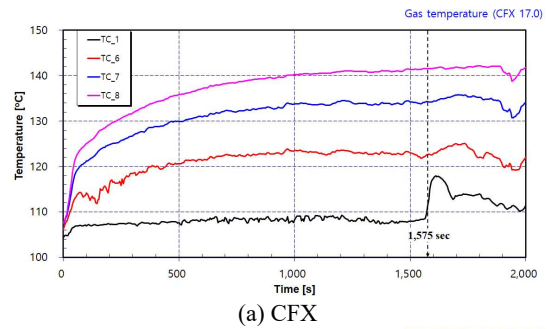

(a) CFX

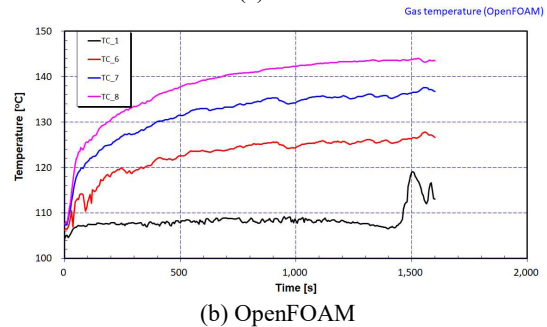

(b) OpenFOAM

Fig. 5. Gas temperature evolution in the vessel.

4.3 Grid wall temperature

Fig. 6 shows the predictions of grid wall temperatures at the positions of 5 thermocouples mounted in the inclined grid. Since the steam jet with high temperature is cooled down before reaching the grid, most of the temperature predictions are below 120°C (Fig. 6-a).

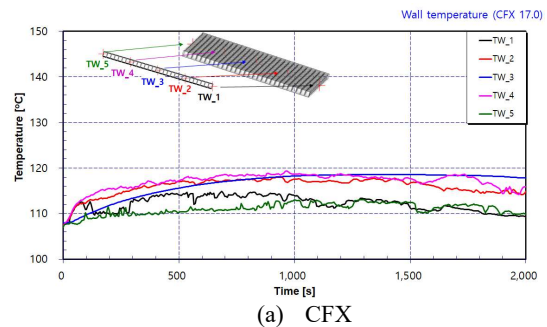

(a) CFX

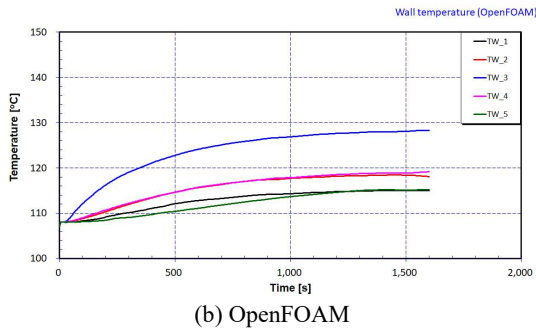

Fig. 6. Grid wall temperature evolution in the vessel.

4.4 Contour of calculation results

Fig. 7 shows the time variation of the calculation results of CFX with contour plots on the x-y plane.

We can see the erosion of the helium layer as time goes on, which can be visualized by helium mole fraction and gas velocity contours. The inclined grid changes the upward jet flow to the right side, and the erosion of the helium layer is performed by this steam jet. The interface of helium and steam layers reaches to top of the vessel at about 1,800 seconds.

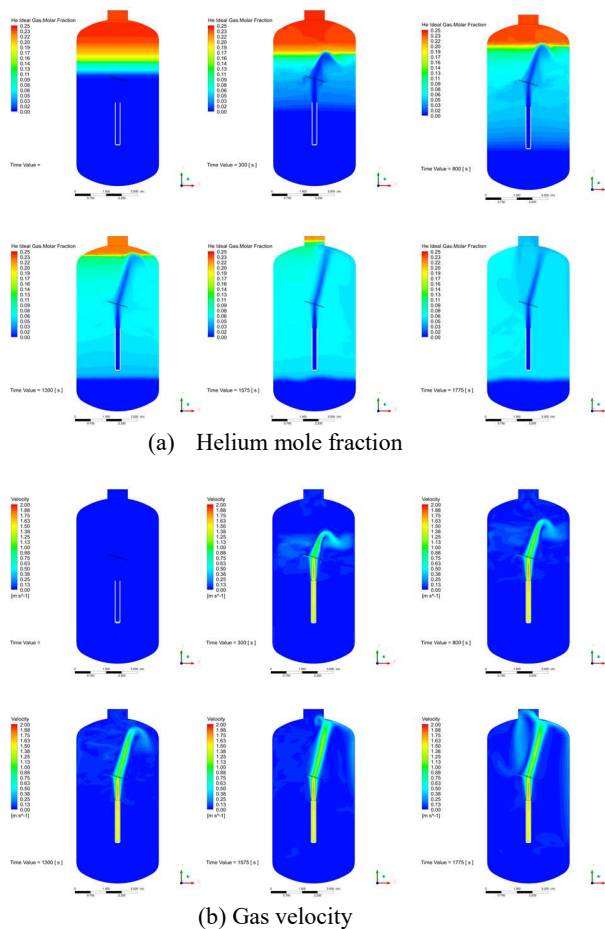

Fig. 7. Two-dimensional contour (on the x-y plane) for calculation results (CFX).

3. Conclusions

In the blind-benchmark calculation of H2P1_10_2 test, selected time-dependent measurements for helium molar concentration, gas temperature, and grid wall temperature are calculated by OpenFOAM ver. 7.0 and ANSYS CFX code. The results of two codes are very similar to each other for time evolution of gas concentration and temperature in the vessel.

These benchmark calculation results will be used for comparison with the test data disclosed in the open-benchmark.

ACKNOWLEDGMENTS

This work was supported by the National Research Foundation of Korea (NRF) grant funded by the Korea government (Ministry of Science, ICT) (No. 2017M2A8A4015277)

REFERENCES

- [1] OECD/NEA, Agreement on the OECD/NEA HYMERES Phase 2 project; to resolve complex safety relevant issues for the analysis and mitigation of a severe accident leading to hydrogen release into a nuclear plant containment and suppression pressure pool system issues, 2017.
- [2] S. Paranjape, S., R. Kapulla, W. Bissels, M. Fehlmann, S. Suter, and D. Paladino, OECD/NEA HYMERES-2 project: PANDA test facility description and geometrical specifications, Paul Scherrer Institut (PSI), Tech. Rep. TM-41-18-02/HYMERES-2-18-02, Rev0. 2018.
- [3] S. Paranjape, S., R. Kapulla, M. Fehlmann, W. Bissels, M. Andreani, and D. Paladino, OECD/NEA HYMERES-2 project: PANDA test H2P1_10_2 Specifications for the blind benchmark with initial and boundary conditions, Paul Scherrer Institut (PSI), Tech. Rep. TM-41-19-15/HYMERES-2-19-13, Rev0. 2019.
- [4] M. Andreania, et. al, Synthesis of a CFD benchmark exercise based on a test in the PANDA facility addressing the stratification erosion by a vertical jet in presence of a flow obstruction, Nuclear Engineering and Design, Vol.354, pp.1-31, 2019.
- [5] ANSYS ICEM CFD, Release 17.0: User's Manual, ANSYS Inc., Canonsburg, PA, USA, January 2016.
- [6] ANSYS CFX-Solver, Release 17.0: Theory Guide, ANSYS Inc., Canonsburg, PA, USA, January 2016.
- [7] H. Weller et al., OpenFOAM: The Open Source CFD Toolbox User Guide, <http://www.openfoam.org>, 2014.