

Proceedings of the Korean Nuclear Society Spring Meeting
Gyeongju, Korea, May 2003

Soft X-ray Emission by Using a Plasma Focus Device

Hyun-Jong Woo, Hyun-Jong You, Yong-Sup Choi, Kyu-Sun Chung,
Chi Young Han, and Jong Kyoung Kim
Hanyang University
17 Haengdang, Seongdong Seoul, Korea 133-791

Joo-Ho Hwang
Kyunghee University
Kiheung, Yongin, Kyunggi, Korea 449-701

Jae-Rok Kim
KDNS
589-6 Banwol, Taean, Hwasung, Kyunggi, Korea 445-973

Abstract

As a pulsed neutron source, a Low Energy Mather-type Plasma Focus (LEMPF) device is developed and preliminary experimental results of x-ray emission with argon gas are presented. The x-ray emission is detected with dental x-ray film (Kodak IP-2) with iron filters of different thicknesses (12.5, 25, 37.5, 50 μm), the energy of x-ray emitted from LEMPF is estimated as 2-4 keV. The stored energy and measured discharge peak current of the LEMPF are 0.784 kJ (capacitor bank: 32 μF and charging voltage: 7kV) and 79kA, respectively.

1. Introduction

The plasma focus device is based on a z-pinch phenomenon of plasma, which is caused by self-generating azimuthally magnetic field of high current in axial direction. Although the plasma focus has been developed

as a thermonuclear fusion device, research on the radiation emissions (x-ray, electron, ion and neutron), which are generated at breaking moment of plasma column ($m=0$ instability), are more active for various industrial applications than the thermonuclear fusion research in these days.¹⁾ The radiation from plasma focus can be used in various areas, such as X-ray spectroscopy, micro-fabrication, microscopy, x-ray laser pumping and micro-electronics lithography.²⁾

In this work, the observation of the soft x-ray emission from LEMPF, and, the estimation of x-ray energy are reported. To optimize the LEMPF, plasma-focusing conditions with argon gas were investigated by measuring discharge voltage and current. The x-ray emission at the moment of plasma focus was detected voltage peak and current drop shows the clear indication of plasma focusing with $m=0$ instability, and leads to generation of x-rays from the surface of copper electrode. The energy of x-ray is to be estimated as 2-4 keV by using x-ray film with various iron foil filters.

2. Experimental Setup

The LEMPF is a Low Energy Mather-type plasma focus device, which has inner electrode of 95 mm height and diameter of 16 mm and outer electrodes of 60 mm in diameter. The inner electrode has hollow at the end to reduce the interaction of electron beam from the focus region with the anode surface, and the outer electrode is cage type of 16 cylindrical rods of copper.³⁾ Pyrex tube of 13mm height is inserted on the inner electrode as an insulator. The power source of LEMPF is a capacitor with capacitance of 32 μF , inductance of 250 nH, and maximum charging voltage of 40 kV. To obtain the optimized operation, i.e., voltage peak and current drops at the peak of half cycle, 7 kV is applied. Field distortion spark gap switch is located between capacitor bank and electrodes and transmission line is connected as short as possible to reduce system inductance. Discharge voltage is measured with high voltage probe between inner and outer electrode, and current is measured with Pearson coil of model No. 101. Due to maximum current of the Pearson coil, ground line of the LEMPF was divided as seven paths and the discharge current was measured from one path with

the coil. Figure 1 shows the schematic diagram of the LEMPF system.

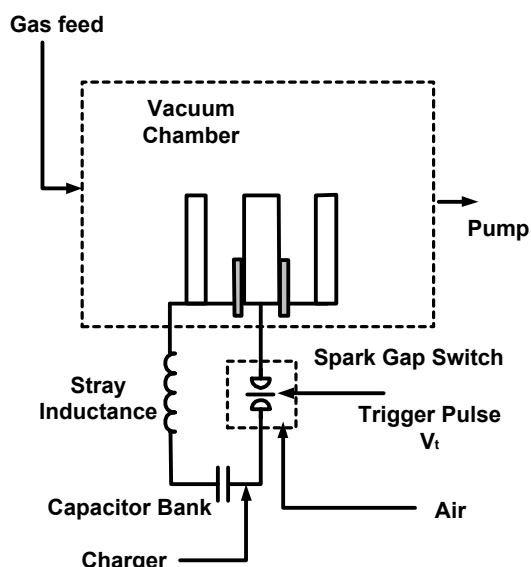
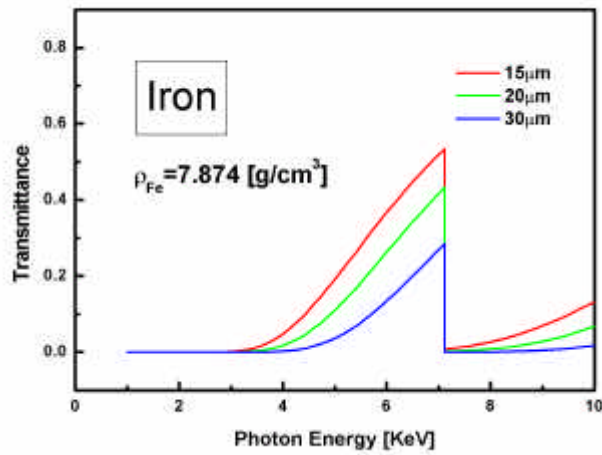
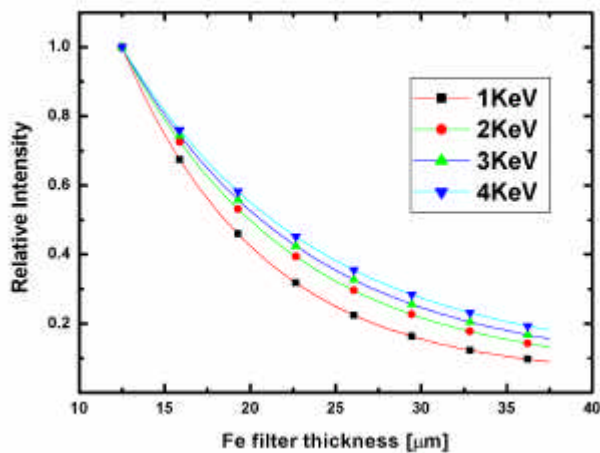

Figure 1 Schematic diagram of the co-axial plasma focus device

The most part of x-ray generation comes from bremsstrahlung radiation of electrons, which is accelerated in the Coulomb field of ions and in the recombination process. Line radiation is always present due to impurities such as carbon, nitrogen and oxygen. In plasma focus devices, the main source of line radiation is the interaction of electron beam from the focus region with anode, which is made of oxygen free copper. When electrons of energy of 10-100 keV impinge on copper target, the dominant line radiation of K (8.05 keV) is generated.³⁾ For a measurement of x-ray energy excluding the line radiation, Fe foil filters with various thickness (12.5, 25, 375, 50 μm) are located in front of the x-ray film, and the filtered film is located at an angle of 90° with the top of the anode. Figure 2 shows transmittance and relative intensities of x-rays with different iron filter thickness and x-ray energy.⁵⁾



(a)



(b)

Figure 2 (a) Transmission Characteristics of Iron filters,
(b) Relative intensity with filter thickness

3. Experimental Results

Plasma is focused, when the driven current and the particles are arrived at the same time on top of the electrodes (i.e., when the magnetic induction becomes maximum.). According to snow-plow model, the plasma focusing condition is considered only to be dependent on the

input gas pressure (p) at constant voltage (or constant current).⁴⁾⁵⁾⁶⁾ If the plasma focus device can be operated with different pressure, therefore, plasma focusing condition is found by choosing the condition of applied voltage and current drop at the peak. We found this condition as $p=1.1$ Torr with charging voltage of 7 kV from our LEMPF. Figure 3 shows that voltage spiking and current dropped when plasma is focused.

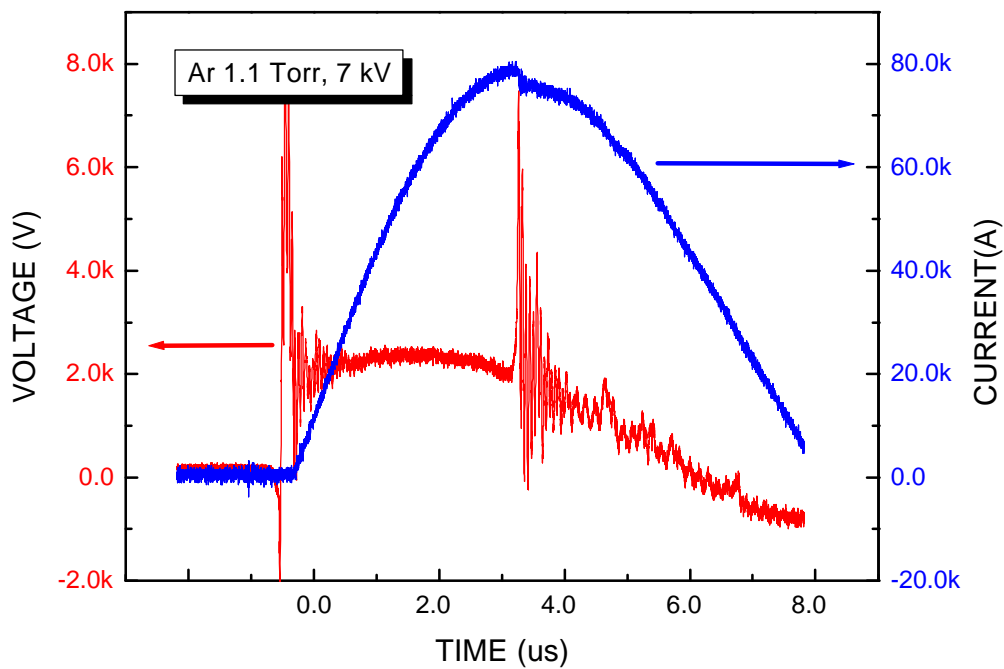
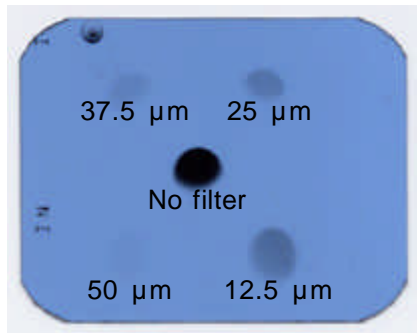

Figure 3. Voltage and Current Signal (Ar, 1.1 Torr, 7 kV)

Using Ar gas, the radiations including x-rays were emitted from the plasma. Figure 4 shows x-ray image film exposed at upper shot and MEDIFACE program of film data processing.



(a)



(b)

Figure 4 (a) x-ray film image exposed and developed
(b) MEDIFACE programs

A Results dealing with x-ray image film by using MEDIFACE programs is that relative intensities are 0.306 (25 μm), 0.21(37.5 μm), and 0.079(50 μm) with assumption of the relative intensity is 1 at 12.5 μm of iron filter. From this, the x-ray energy is estimated as 2-4 keV (Figure 2 (b)).

4. Conclusions and Future Works

Optimized plasma focusing condition in an LEMPF is found as the following: pressure 1.1 Torr and charging voltage in 7 kV. The energy of x-ray emitted from a plasma focus device is estimated as 2-4 keV excluding the line radiation. In future, the energy of x-ray will be detected by using x-ray detector with good resolutions. As different charged voltage and different angle on the top of anode, the x-ray energy distributions are also to be estimated. Furthermore, a pulsed neutron, a final goal of this focus device, will be generated by using deuterium gas.

Acknowledgement

This work was partially supported by the research grants of

Innovative Technology Center for Radiation Safety (iTRS) in Hanyang University. We would also like to thank Diagnostic Radiology and Dental Clinic team in Hanyang University Medical Center, and Su-In Dental Clinic for their help with the film developing and data processing.

References:

- 1) Cesar Moreno, Horacion Bruzzone, Javier Martinez, and Alejandro Clause, "Conceptual Engineering of Plasma-Focus Thermonuclear Pulsors", IEEE Transactions on Plasma Science, 28, 5, 1735-1741 (2000)
- 2) P.X. Feng, B. James, M. H. Liu, S. Lee, and Y.H. Chen, "A pinhole transmission grating spectrograph used in the characterization of the spatial distribution plasma x-ray spectrum", Plasma Sources Sci. Technol., 10, 343-348 (2001)
- 3) M. Zakauallah, Khalid Alamgir, M. Shafiq. S.M. Hassan. G. Murtaza and A. Waheed, "Improved temperature measurement in a plasma focus by means of a cobalt filter", Plasma Sources Sci. Technol., 10, 295-301 (2001)
- 4) M.A. Liberman, J.S. De Groot, A. Toor, R.B. Spielman, "Physics of High-Density Z-Pinch Plasmas", Springer (1998)
- 5) Jae-Rok Kim, "Study on the Pulsed Neutron generation by a Plasma Focus Device", Hanyang University (2001)
- 6) S. Lee, B.C. Tan, C.S. Wong, A.C. Chew, "Laser and Plasma Technology", World Scientific (1985)