

## Modification of Prototype D-D Neutron Generator

In Jung Kim, Suk-Kwon Kim, Chang Su Park, Nam-Suk Jung, Hwa-Dong Jung, Ji-Young Park,  
 Yong-Seok Hwang and H.D. Choi

Seoul National University, Shinlim-Dong, Gwanak-Gu, Seoul 151-742, Korea, vandegra@plaza.snu.ac.kr

### 1. Introduction

The prototype D-D neutron generator [1~6] was modified in order to enhance the neutron yield. The distance from ion source to target was reduced to increase the ion beam current at target position. Thick Ti target was replaced by thin Ti target which was vacuum-deposited on Cu substrate in order to enhance the target cooling. Performance of the modified device was tested.

### 2. Experimental apparatus

Schematic construction of the device is shown in figure 1. The composition of the device is the same as written in reference [6]. Some modification was made to target and the related components and detector was re arranged, too.

The distance from ion source to target was reduced. Ion beam collimator, suppression electrode and target were placed at 99 mm, 176 mm and 211 mm away from plasma electrode of ion source, respectively. The apertures of ion beam collimator and suppression electrode were adjusted to 16 mm $\Phi$ , 45 mm $\Phi$ , respectively. Target assembly was modified in order to enhance the target cooling performance. Thick Ti target (0.5 mm) was replaced by thin Ti target (10  $\mu$ m) deposited on Cu substrate. Coolant channel to target was expanded and the coolant flow rate was increased. The resistance of the resistor which couples suppression electrode and target was adjusted to 1 M $\Omega$ . The Si detector was placed at 112 mm away from the center of target and 118 $^\circ$  off the beam direction. The detector was covered with a beam stopper foil of 36  $\mu$ m Al and the detection area was defined by an aperture of 1.3 mm $\Phi$ .

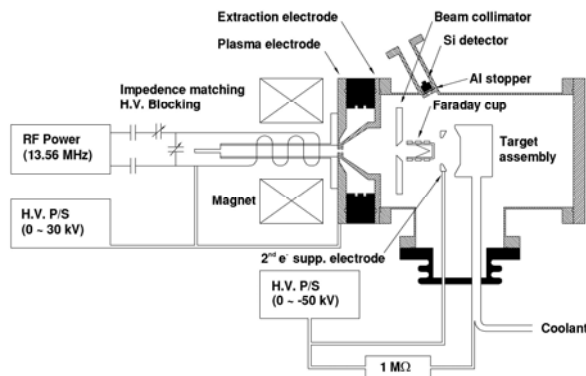

Figure 1. Schematic drawing of the modified prototype D-D neutron generator.

### 3. Experiment and results

The plasma source was turned on with 1.0 kW RF power, and the deuteron beam was extracted at 20 kV from ion source. Deuteron beam current was 2.9 mA at target position. Bias voltage of -30 kV, -35 kV, -40 kV was applied to suppression electrode, consequently. Voltage drop was 2.9 kV across the 1 M $\Omega$  resistor between suppression electrode and target hence, the target potential was -27.1 kV, -32.1 kV, -37.1 kV, respectively.

After deuteron beam irradiation was terminated, the beam left a circular mark. Diameter of the beam mark was 15 mm $\Phi$ . The mark was regarded as the region of neutron generation, and the detector solid angle was determined. The detector solid angle was  $9.9 \times 10^{-5}$  sr. The proton peak spectrum was observed at 2.0 MeV. The measured spectrum of proton from D(d,p)T reaction by using Si detector is shown in figure 2.

The determined neutron yield is shown in figure 3

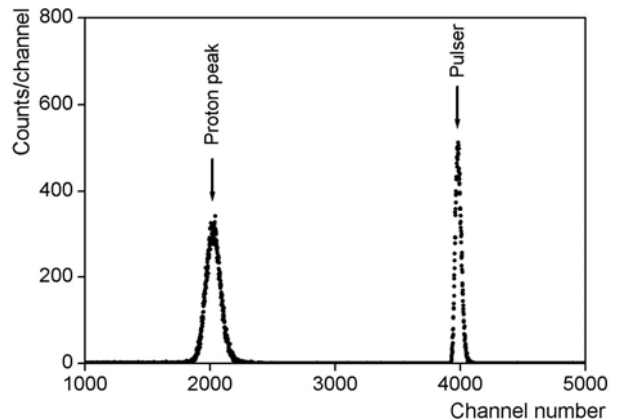

Figure 2. Measured proton peak spectrum from D(d,p)T reaction. Incident deuteron beam energy is 57.1 keV.

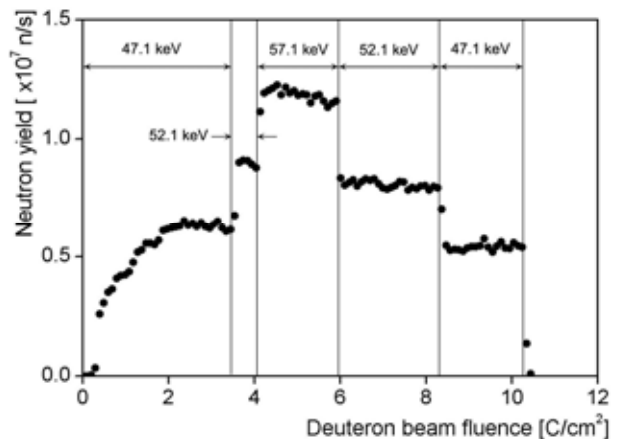

Figure 3. Neutron yield vs. deuteron beam fluence.

according to deuteron beam fluence. In this figure, until the deuteron beam fluence was accumulated to  $3.5 \text{ C/cm}^2$ , the target was biased to  $-27.1 \text{ kV}$  and ion beam energy was  $47.1 \text{ keV}$ . In this period, neutron yield was increased as an exponential decay function, and the asymptotic upper bound was about  $6.5 \times 10^6 \text{ n/s}$ . After this period, the deuteron beam was accelerated up to  $52.1 \text{ keV}$ ,  $57.1 \text{ keV}$  and neutron yield was increased up to  $1.2 \times 10^7 \text{ n/s}$ .

#### **4. Conclusion**

The device was modified and neutron yield was enhanced. Ion beam current was increased and thin Ti target being vacuum-deposited on Cu was used. As a result, neutron yield of  $1.2 \times 10^7 \text{ n/s}$  was achieved with  $2.9 \text{ mA}$ ,  $57.1 \text{ keV}$  deuteron beam.

#### **REFERENCES**

- [1] In Jung Kim and H.D. Choi, Conceptual Design of a D-D Neutron Generator, Proceedings of the Korean Nuclear Society Autumn Meeting, Oct. 2002, YongPyong, Korea.
- [2] In Jung Kim, Sun-Ho Kim and H.D. Choi, Design of a Prototype D-D Neutron Generator and Shielding Calculation, Proceedings of the Korean Nuclear Society Spring Meeting, May 2003, Gyeongju, Korea.
- [3] In Jung Kim, Nam-Suk Jung and H.D. Choi, Development of Prototype D-D Neutron Generator, Proceedings of the Korean Nuclear Society Spring Meeting, May 2004, Gyeongju, Korea.
- [4] In Jung Kim and H.D. Choi, Development of D-D Neutron Generator, 18th International Conference on the Application of Accelerators in Research and Industry, Oct. 2004, Fort Worth, USA.
- [5] In Jung Kim, Suk-Kwon Kim, Chang Su Park, Nam-Suk Jung, Hwa-Dong Jung, Ji-Young Park, Yong-Seok Hwang and H.D. Choi, Experiment of Neutron Generation by Using Prototype D-D Neutron Generator, Proceedings of the Korean Nuclear Society Spring Meeting, May 2005, Jeju, Korea.
- [6] In Jung Kim, and H.D. Choi, Development of D-D Neutron Generator, Nuclear Instruments and Method B, in press, 2005.